

Part 4

Control System

1. Outline of Operation Control by Microcomputer	386
1.1 Wired Remote Controller (Optional Parts)	386
1.2 Setting Functions Using the Remote Controller	387
2. Operation Control Function by the Indoor Controller	391
3. Operation Control Function by the Outdoor Controller	399
3.1 Standard Multi-Unit FDCA140HKXE4	399
3.1.1 Compressor operating frequency decision	399
3.1.2 Compressor starting control	399
3.1.3 Outdoor fan control	400
3.1.4 Silent mode control	401
3.1.5 Defrosting	401
3.1.6 Cooling and heating forced operation	403
3.1.7 Compressor protective control	403
3.1.8 Oil separator bypass valve (SV3) control (SV2 is always turning ON while the compressor is operating.)	406
3.1.9 Refrigerant recovery control	406
3.1.10 Abnormal stop due to abnormal compressor start	406
3.1.11 Compressor abnormal rotor lock	406
3.1.12 Test operation	407
3.1.13 Pump down control	407
3.1.14 Thermistor and pressure sensor disconnection (discharge · suction · outdoor heat exchanger · under-dome, outdoor air, temperature)	407
3.1.15 External input operation and demand input operation	408
3.1.16 7-Segment display	410
3.1.17 Saving of Operation Data	415
3.2 Standard Multi-Unit FDCA224, 280, 335HKXE4	420
3.2.1 Operations of major functional items under each operation mode	420
3.2.2 Oil separator solenoid valve (SV6) control	420
3.2.3 Control of increasing and decreasing of compressor frequency	421
3.2.4 Outdoor fan control	421
3.2.5 4-way valve switching assurance	421
3.2.6 Compressor protective start	422
3.2.7 Crankcase heater control	422
3.2.8 Cooling high pressure control	423
3.2.9 Cooling low pressure control	423
3.2.10 Heating high pressure control	423
3.2.11 Heating low pressure control	424

3.2.12	Sub cooling coil control	424
3.2.13	Defrosting	425
3.2.14	Inverter cooling fan control	426
3.2.15	Unit protective maintenance related devices	426
3.2.16	Silent mode control	430
3.2.17	Oil return control	430
3.2.18	Forced heating/cooling operation	431
3.2.19	Snow protection fan control	431
3.2.20	Pump down control	431
3.2.21	Indoor unit refrigerant recovery control	432
3.2.22	Emergency stop control	432
3.2.23	Compression ratio protection control	432
3.2.24	Indoor unit connection number protection	433
3.2.25	External input operation and demand input operation	433
3.2.26	7-Segment display	435
3.2.27	Saving of Operation Data	440
3.3	Standard Combination Multi-Unit FDCA335HKXE4-K, FDCA400HKXE4 ~ FDCA1360HKXE4	446
3.3.1	Operations of major functional items under each operation mode	446
3.3.2	Compressor starting order and load classes	446
3.3.3	Compressor start control between outdoor units (Main unit / sub (remote) unit)	447
3.3.4	Starting the compressor (Main unit / sub unit)	448
3.3.5	Compressor pre-start control (Main unit / sub unit)	449
3.3.6	Oil separator solenoid valve (SV6, 7) control	450
3.3.7	Outdoor fan control (Main unit / sub unit)	451
3.3.8	Crankcase heater control	451
3.3.9	Cooling high pressure control	452
3.3.10	Cooling low pressure control (Main unit)	452
3.3.11	Heating high pressure control (Main unit only)	453
3.3.12	Heating low pressure control (Main unit / sub unit)	453
3.3.13	Sub cooling coil control	454
3.3.14	Defrosting (Main unit / sub unit)	455
3.3.15	Indoor unit refrigerant recovery control	456
3.3.16	Silent mode control (Main unit / sub unit)	456
3.3.17	Compression ratio protection control	457
3.3.18	Oil return control (Main unit / sub unit)	457
3.3.19	Oil equalization rotation (Main unit / sub unit)	458
3.3.20	Oil equalization control (Main unit / sub unit)	459
3.3.21	Inverter cooling fan control (Main unit/sub unit)	461
3.3.22	Unit protective maintenance related devices (Main unit only)	461
3.3.23	Forced heating / cooling operation (Main unit)	466
3.3.24	Automatic backup operation (Main unit / sub unit)	466
3.3.25	Snow protection fan control (Main unit / sub unit)	466
3.3.26	Pump down control (Main unit / sub unit)	467
3.3.27	Emergency stop control	468
3.3.28	Ventilation fan control (Main unit / sub unit)	468
3.3.29	Outdoor unit combination protection (Main unit only)	469

3.3.30	Indoor unit connection number protection (Main unit only)	469
3.3.31	External input operation and demand input	469
3.3.32	7-Segment display	472
3.3.33	Saving of operation data	477

1. Outline of Operation Control by Microcomputer

1.1 Wired Remote Controller (Optional Parts)

The figure below shows the remote controller with the cover opened. Note that all the items that may be displayed in the liquid crystal display area are shown in the figure for the sake of explanation.

Characters displayed with dots in the liquid crystal display area are abbreviated.

Pull the cover downward to open it.

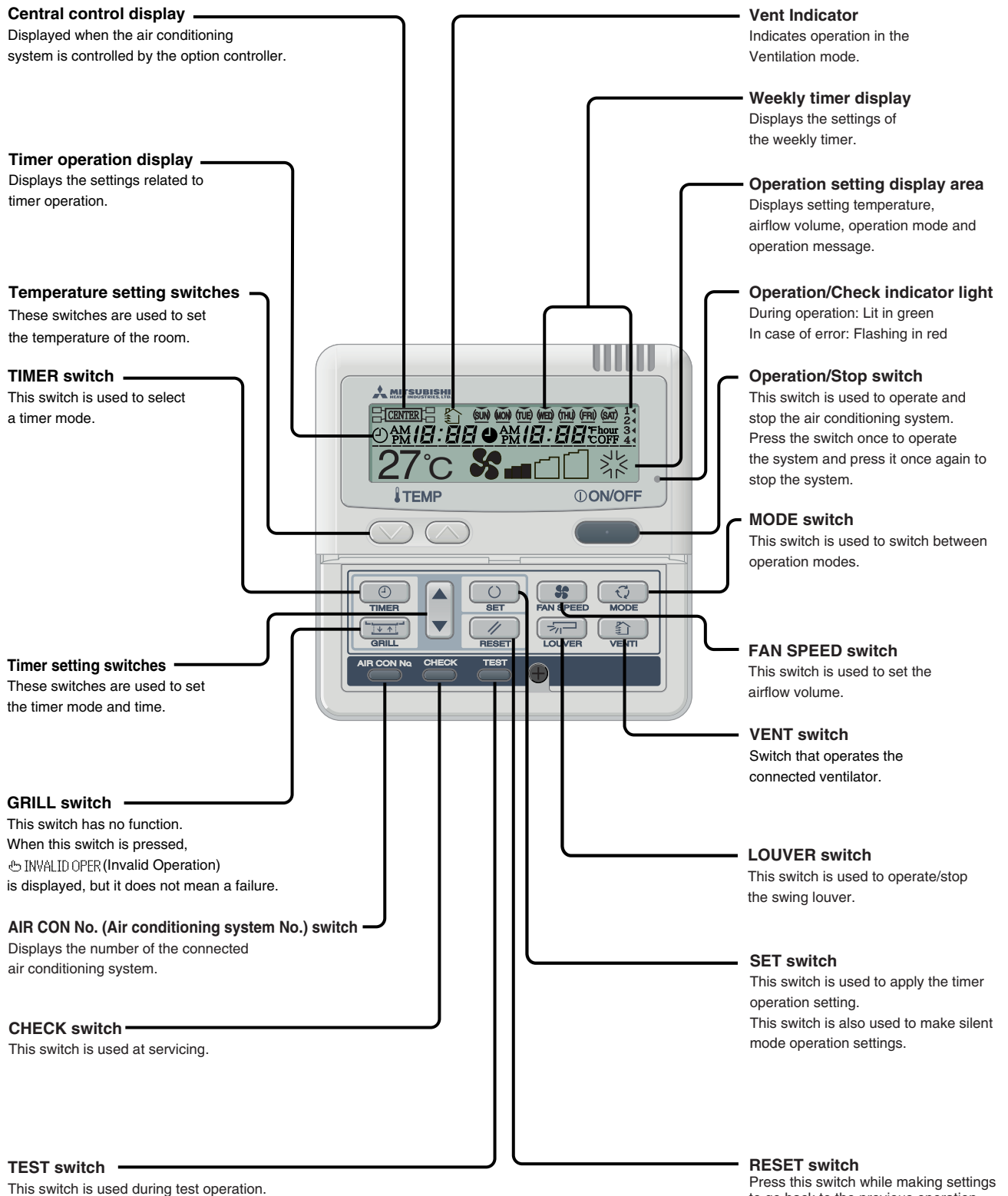























* If you press any of the switches above and "INVALID OPER" is display, the switch has no function. But it does not mean a failure.

1.2 Setting Functions Using the Remote Controller

- The default settings of this unit's functions are as follows: If you want to change a setting, follow the procedure found in the installation manual and set to your desired setting.

For the method of setting, please refer to the installation manual of a remote controller.



Remote control unit functions ( FUNCTION ▼)

Function number [Ⓐ]	Function description [Ⓑ]	Setting [Ⓒ]	Default setting
01	GRILLE \updownarrow SET (Grille lift panel setting)	\updownarrow INVALID	<input type="radio"/>
		50Hz AREA ONLY	
		60Hz AREA ONLY	
02	AUTO RUN SET	AUTO RUN ON	*
		AUTO RUN OFF	
03	 TEMP S/W	 VALID	<input type="radio"/>
		 INVALID	
04	 MODE S/W	 VALID	<input type="radio"/>
		 INVALID	
05	 ON/OFF S/W	 VALID	<input type="radio"/>
		 INVALID	
06	 FANSPEED S/W	 VALID	<input type="radio"/>
		 INVALID	
07	 LOUVER S/W	 VALID	*
		 INVALID	
08	 TIMER S/W	 VALID	<input type="radio"/>
		 INVALID	
09	 SENSOR SET (Remote control sensor setting)	 SENSOR OFF (Invalid)	<input type="radio"/>
		 SENSOR ON (Valid)	
10	POWER FAILURE COMPENSATION SET	INVALID	<input type="radio"/>
		VALID	
11	VENTI SET	NO VENTI	<input type="radio"/>
		VENTI LINK SET	
		NO VENTI LINK	
12	TEMP RANGE SET	DISP CHANGE	<input type="radio"/>
		NO DISP CHANGE	
13	I/U FAN SPEED (Indoor unit fan speed setting)	3 FAN SPEED	*
		2 FAN SPEED	
		1 FAN SPEED	
14	MODEL TYPE	HEAT PUMP	*
		COOLING ONLY	
15	EXTERNAL CONTROL SET	INDIVIDUAL OPERATION	<input type="radio"/>
		SAME OPERATION FOR ALL UNITS	
16	ERROR DISP SET	ERROR DISP	<input type="radio"/>
		NO ERROR DISP	
17	 POSITION (Louver control setting)	FIX (1 OF 4) (4 position stop)	<input type="radio"/>
		IN MOTION (Free stop)	
18	°C/°F SET	°C	<input type="radio"/>
		°F	



Notes(1) Setting marked with are the default setting.

- (2) Setting marked with [*] are those that are set automatically according to an indoor unit or an outdoor unit connected.

Please check default settings with the indoor unit's installation manual.

- (3) When Item 17 : " POSITION" is changed, please also change Item 04 " POSITION" setting found in "Indoor unit functions".

Indoor unit functions (I/U FUNCTION ▲)

Function number [Ⓐ]	Function description [Ⓑ]	Setting [Ⓒ]	Default setting
01	Hi CEILING SET	STANDARD	*
		Hi CEILING 1	
03	FILTER SIGN SET	NO DISPLAY	
		AFTER 180H	
		AFTER 600H	<input type="radio"/>
		AFTER 1000H	
04	 POSITION (Louver control setting)	FIX (1 OF 4) (4 position stop)	<input type="radio"/>
		IN MOTION (Free stop)	
05	EXTERNAL INPUT SET	LEVEL INPUT	<input type="radio"/>
		PULSE INPUT	
06	OPERATION PERMISSION PROHIBITED	NORMAL OPERATION	<input type="radio"/>
		VALID	
07	 ROOM TEMP OFFSET (Heating room temperature offset)	NORMAL OPERATION	<input type="radio"/>
		TEMP SHIFT +3°C	
08	 FAN CONTROL (Heating fan control)	LOW FAN	*
		STOP→LOW FAN (Intermittent operation)	
09	FREEZE PREVENT TEMP	TEMP Hi	
		TEMP Lo	<input type="radio"/>
10	FREEZE PREVENT CONTROL	FAN CONTROL ON	<input type="radio"/>
		FAN CONTROL OFF	
11	ELECTR DUST COLLEOR	FAN CONTROL OFF	<input type="radio"/>
		FAN CONTROL ON	
12	HUMIDI CONTROL	DM LINK OFF	<input type="radio"/>
		DM LINK ON	

Notes(1) Setting marked with are the default setting.

- (2) Setting marked with [*] are those that are set automatically according to an indoor unit or an outdoor unit connected. Please check default settings with the indoor unit's installation manual.

2. Function setting method
 - 1) Stop the air conditioner

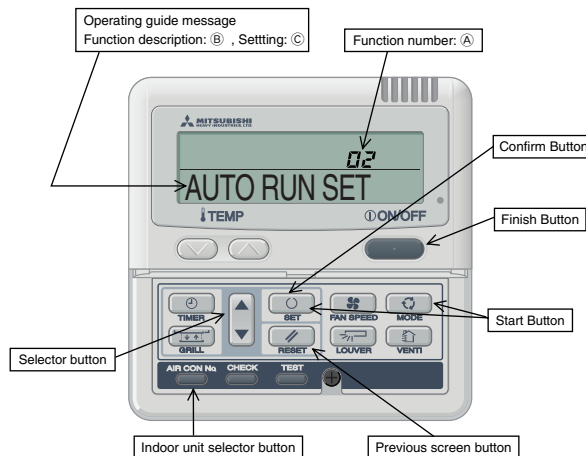

- 2) Press the SET and MODE buttons simultaneously for 3 seconds or longer. The screen display will be switched as follows:

" SELECT ITEM " → " SET " → "FUNCTION SET ▼ "



- 3) Press the SET button. The unit will enter the function setting mode. The screen display will change to " FUNCTION ▼ ".
- 4) Check which category your desired setting belongs to, " FUNCTION ▼ (Remote controller unit function)" or " I/U FUNCTION ▲ "(Indoor unit function).
- 5) Press either ▲ or ▼ button. Select either " FUNCTION ▼ " or " I/U FUNCTION ▲ "



- 6) Press the SET button.
 - When " FUNCTION ▼ " is selected.
 - ① "DATA LOADING" (blinking) → " FUNCTION " → " 01 GRILLE ↑↓ SET " (Function number: A, Function description: B)
The screen display will be switched like this.
 - ② Press either ▲ or ▼ button.
"Function number: A, Function description: B" from the list of remote controller unit functions will be displayed one by one. Select a desired function.
 - ③ Press the SET button.
The screen display will be switched as follows:
" SETTING " → "Setting: C" (ex. "AUTO RUN ON")
 - ④ Press either ▲ or ▼ button.
A list of "Settings: C" will be displayed one by one. Select your desired setting.

- ⑤ Press the SET button.
The selected setting is displayed for 2 seconds, then followed by "SET COMPLETE" and the function setting process is completed. Then the screen display will be switched to "Function number: (A), Function description: (B)," so if you want to continue to set another function, repeat the steps as explained above. To finish the function setting process, please proceed to Step (c).

* When "02 AUTO RUN SET" is selected.

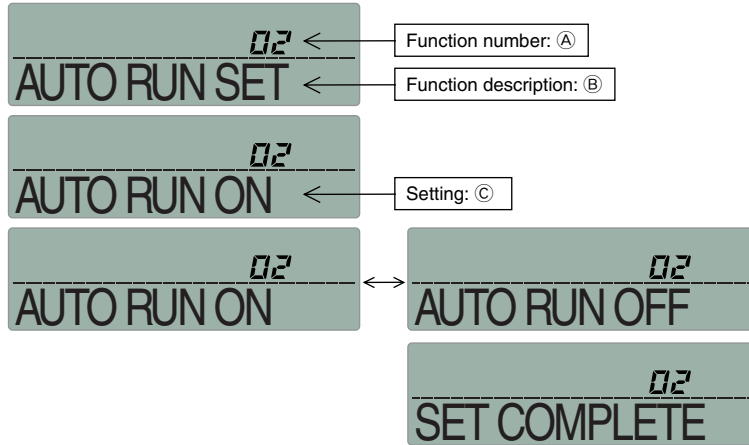

■ When "I/U FUNCTION ▲" is selected.

- ① The screen display will be switched as follows:
" I/U SELECT" → " I/U SET" → "I/U No.00" (blinking)

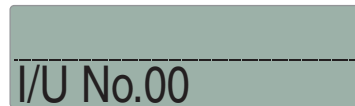

- ② Press either ▲ or ▼ button.
Select the indoor unit number that you want to change settings. If only one indoor unit is connected, the indoor unit number will not change, so please proceed to Step ③.
If "ALL I/U ▼" is selected while indoor group control is in effect, you can set all units to the same settings.

- ③ Press the SET button.
Indoor unit number indication will change from blinking to lit continuously, The screen display will be switched as follows:
"DATA LOADING" (blinking for about 2 to 23 seconds) → " I/U FUNCTION" → "01 Hi CEILING SET" (Function number: (A), Function description: (B))

* When "01 Hi CEILING SET" is selected.



- ④ Press either ▲ or ▼ button.
"Function number: (A), Function description: (B)" from the list of indoor unit functions will be displayed one by one. Select a desired function.
- ⑤ Press the SET button.
The screen display will be switched as follows: " I/U SETTING" → "Setting: (C)" (ex. "STANDARD")

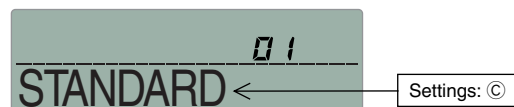

- ⑥ Press either ▲ or ▼ button.
A list "Setting: (C)" will be displayed one by one. Select your desired setting.
- ⑦ Press the SET button.
The selected setting is displayed for 2 seconds, then followed by "SET COMPLETE" and the function setting process is completed.
Then the screen display will be switched to "Function number: (A), Function description: (B)" so if you want to continue to set another function, repeat the steps as explained above. To finish the function setting process, please proceed to Step 7).

- ⑧ Press AIR CON No. button.
The screen display will go back to the indoor unit selection screen (ex. " I/U No.00").
If you want to continue to set another indoor unit, please follow the steps explained above.
- 7) Press the ON/OFF button.
This ends a function setting process. Even if a function setting process is not completed, this ends the process. Please note that any setting that is not completed will become void.
 - Pressing the RESET button during a function setting process will allow you to go back the previous step. Please note that any setting that is not completed will become void.
 - Method of checking the current setting
While following the above mentioned step, the setting that appears when the SET button is pressed for each "Function number: ①, Function description: ②" is the current setting "Setting: ③". (When "ALL I/U ▼" is selected, the setting of the indoor unit with the lowest number is displayed)
 - Settings are stored in the controller and not lost even a power outage occurs.
- 3. Changing the remote controller's temperature setting range
 - 1) The temperature setting range of the remote controller can be changed.
Through remote controller button operations, the upper limit and lower limit set temperature values can be changed individually.
During heating operation, the changed upper limit value becomes valid and at times other than during heating operation, (during cooling, dehumidification, auto and fan operation), the changed lower limit value becomes valid.
Range of Possible Changes
Upper Limit Value: 22~30°C (valid during heating) Lower Limit Value: 18 ~ 26°C (valid at times other than during heating)
 - 2) Operation
 - a) With the remote controller in the stopped state, press the SET and MODE buttons simultaneously for 3 seconds or longer.
The display will changed from "SELECT ITEM" → "SET" → "FUNCTION SET ▼"
 - b) Press the [DOWN] button once. The display will change to TEMP RANGE ▲.
 - c) Press the SET button to enter the temperature range setting mode.
 - d) Using the [UP] or [DOWN] button, select "Hi LIMIT SET ▼" or "Lo LIMIT SET ▲", the press the SET button.
 - e) If "Hi LIMIT SET" is selected,
 - ① The display changes from "SET UP" → "Hi LIMIT 22°C ▲" (flashing).
 - ② Using the [DOWN] [UP] button, select the upper limit value. Display example: "Hi LIMIT 22°C ▲" (flashing)
 - ③ Press the SET button to fix the setting. Display example: "Hi LIMIT 22°C" (lighted up)
 - f) If "Lo LIMIT SET" is selected,
 - ① The display changes from "SET UP" → "Lo LIMIT 26°C ▼" (flashing).
 - ② Using the [DOWN] [UP] button, select the upper limit value. Display example: "Lo LIMIT 26°C ▼" (flashing)
 - ③ Press the SET button to fix the setting. Display example: "Lo LIMIT 26°C" (lighted up)
 - g) Press the ON/OFF button to end the setting procedure.
(The procedure also ends if the ON/OFF button is pressed during the setting operation. However, settings which have not been fixed become invalid, so exercise caution.)
 - If the RESET button is pressed during a setting operation, the display returns to the previously displayed setting screen. However, settings which have not been fixed become invalid, so exercise caution.
 - * If "NO DISP CHANGE" is selected in No. 12, "TEMP RANGE SET" of the remote controller's functions, of the function setting modes, the remote controller's display does not change even if the temperature range has been changed.
(Example) If the upper limit is set at 28°C

Function No. A	Function Contents B	Setting Contents C	Control Contents
12	TEMP RANGE SET	DISP CHANGE	The remote controller's display and sent data upper limit changes to 28°C.
		NO DISP CHANGE	The remote controller's display upper limit remains at 30°C and only the upper limit of the sent data is changed to 28°C.

2. Operation Control Function by the Indoor Controller

1. Cooling operation

a) Cooling

- 1) If the sum of selected and required frequencies is not larger than the maximum frequency, the required frequencies listed in the following table apply. If the sum of required frequencies is larger than the maximum frequency, the required frequencies divided proportionally apply.

Frequency bands for indoor unit models

Model(Indoor) Category	All series								
	22 model	28 model	36 model	45 model	56 model	71 model	90 model	112 model	140 model
Required frequency (Hz)	5~15	5~20	5~24	5~27	5~30	5~40	5~50	5~60	5~70
Selected frequency (Hz)	5~15	5~20	5~24	5~27	5~30	5~40	5~50	5~60	5~70

Note (1) The required frequency is counted in the unit and the selected frequency in the unit of 1 Hz.

- 2) This indoor unit electronic expansion valve (EEV) controls opening of each indoor unit corresponding to decision frequency. Also, the thermostat is sampled in pitch of 20 second.

b) Cooling thermostat off

- 1) Fan control operates the thermostat as shown in the following diagram.

If the thermostat goes ON, even if the thermostat is OFF as shown in the following diagram, the thermostat does not go OFF for 2 minutes after the compressor goes ON. If the thermostat goes OFF within 2 minutes, a minimum required frequency other than 0 Hz is output.

- 2) If all the thermostats for indoor units in a module go OFF, outdoor units carry out cooling thermostat OFF operation in modular units.

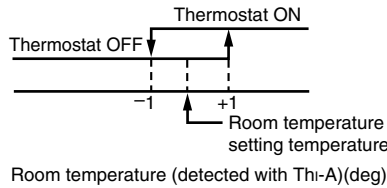

2. Dehumidifying (Thermal dry)

- a) This cooling operation is mainly for dehumidifying, with which the compressor, indoor and outdoor fans are operated in the patterns as listed in the following table and in accordance with operation blocks switched with the room temperature sensor. The operation blocks are selected by checking the return air temperature at 4-minute intervals. Respective functional items are operated in each operation block as shown by the following table.

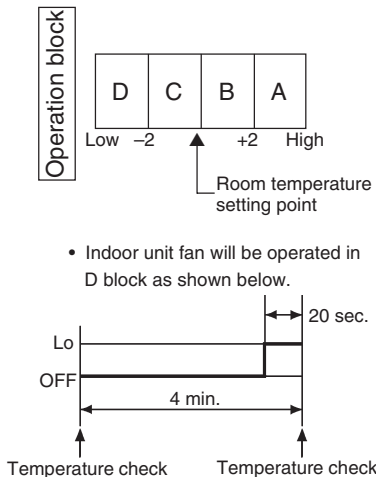

Item		Operation block			
		A	B	C	D
Indoor unit frequency (Hz)	22 model	10	10	10	0
	28 model	15	10	10	0
	36 model	20	15	10	0
	45 model	20	15	10	0
	56 model	25	15	15	0
	71 model	30	20	15	0
	90 model	45	30	25	0
	112 model	50	40	35	0
	140 model	60	45	35	0
Compressor		Sum of frequencies on combined indoor units			
Indoor unit electronic expansion valve		Superheat control			
Indoor unit fan	3 speed model	Me	Lo	Lo	Lo ↔ OFF
	2 speed model	Hi	Lo	Lo	Lo ↔ OFF
Outdoor unit fan		Operation	Operation	Operation	Stop

3. Heating operation

a) Heating

- This is same as the cooling operation.

b) Heating operation with thermostat OFF

- 1) The thermostat operates as shown in the following diagram through fuzzy control.

If the thermostat goes ON, even if the thermostat is off in the following diagram, it doesn't go OFF for 2 minutes after the compressor goes ON. If the thermostat goes OFF within 2 minutes, a minimum required frequency other than 0 Hz is output.

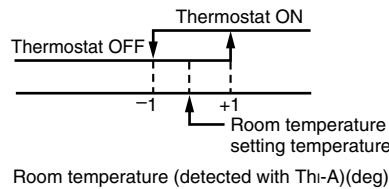

- 2) If all the thermostats for indoor units in a module go OFF, outdoor units carry out heating thermostat OFF operation in modular units.

3) Intermittent fan operation control

- a) When the jumper wire J3 (SW7-3), J4 (SW-7) on the indoor PCB is shorted (installed at shipping), the fan of the unit of which the thermostat is turned OFF during heating is operated in the Lo mode, and the indoor fan is turned OFF if the temperature rises 1°C or more than the return air temperature at the thermostat OFF.
- b) Indoor fan OFF condition is maintained for 5 minutes and then the operation is reset at the Lo mode again. After operating for 2 minutes in the Lo mode, return air temperature is checked and, if it is 1°C or higher, the indoor fan is turned OFF or, if it is not higher than 1°C, the Lo mode operation continues.

Notes (1) If the heating thermostat has been turned OFF, the temperature is indicated on the remote controller only when the indoor fan is operated in the Lo mode. When it is OFF, the room temperature at the end of Lo operation is indicated.

(2) If the operation is changed to the defrosting mode while the heating thermostat is at OFF or the thermostat is turned OFF during defrosting, the indoor fan is turned OFF.

(3) Residual operation of heater is dominant over this control.

4) Fan Lo Operation Control

If jumper wire J4 (SW7-4) on the indoor PCB (set at shipping) is disconnected, indoor units with the thermostat turned OFF during heating operation will operate with the fan on Lo.

5) Fan stop control

- a) If the jumper wire J3 (SW7-3) on the indoor PCB (installed at shipment) is opened or the thermostat is turned OFF during heating operation with the remote control sensor operating, the fan on the indoor unit is turned OFF.

c) Hot start (Prevention of cold draft during heating)

- 1) If the required frequency in the room is other than 0 Hz at the start of heating operation, the indoor fan is controlled in accordance with the temperature of indoor air heat exchanger (detected with Thi-R1, R2).

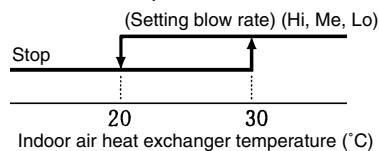

Notes (1) If it is turned OFF forcibly for 1 minute after starting, and after one minute the indoor temperature exceeds 30°C, then this becomes flow rate setting.

(2) When the hot start (the compressor is operating and the indoor unit fan is not operating at the setting blow rate) is going on, the heating preparation is displayed (LCD on the remote controller).

(3) When the required frequency is other than 0 Hz, once the blower should start, it will not stop even if the temperature drops below 20°C.

- 2) During heating, the required frequency becomes 0 Hz (heating thermostat OFF), then afterward, if the required frequency is other than 0 Hz, and the answer back frequency from the outdoor unit is other than 0 Hz (during thermostat reset), hot start control is carried out.

- 3) If the indoor fan motor is OFF continuously for 7 minutes due to hot start control, the indoor fan motor goes ON regardless of the temperature detected by the heat exchanger temperature thermistor (Thi-R1, R2) and "Heating Preparation" LCD goes off.

- 4) Even if the fan motor is stopped continuously for 7 minutes during defrosting, it is not turn ON forcibly, but after defrosting is completed, if the fan motor is OFF continuously for 7 minutes, it is turned ON regardless of the temperature detected by the heat exchanger temperature thermistor (Thi-R1, R2).

d) Residual operation of humidifier

The fan does the residual operation for 30 minutes by turning on SW5-2 on the indoor PCB to prevent the overflow water that stays in the drain pan from evaporating again after the humidifying operation ends, when it is stopped and thermostat is turned off.

Notes (1) During the compressor stop and the abnormal stop and defrosting, doesn't execute this process.

(2) Residual operation of heater is dominant over this control.

4. Value shift adjustment of room air temperature detection in heating

Under the standard specifications, the room temperature is adjusted at the setting temperature by controlling the indoor unit capacity based on the setting temperature of thermostat and the suction air temperature. However, where the unit is installed in the ceiling and warm air tends to stay around the ceiling, temperature in the living space may not be adjusted at the setting temperature. If "ROOM TEMP OFFSET" (heating space temperature compensation) is set in the remote controller's functions, the thermostat is set to go OFF at a temperature which is 3 degrees higher than the space temperature setting, enabling an improved feeling of warmth in the room.

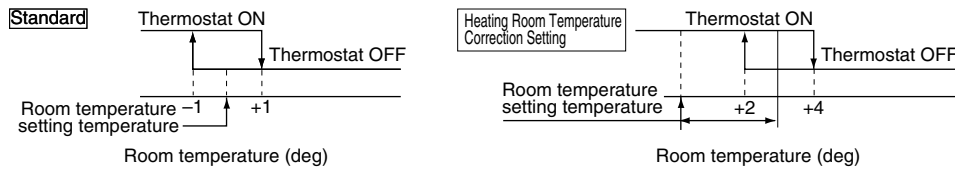

5. Heater control

a) If an optional electric heater is installed, the heater can be controlled by turning the relay (52H-optional for DC12V) on and off according to the temperatures detected with room temperature sensor (THi-A) and air heat exchanger temperature sensor (THi-R1, R2).

■ Room temperature (THi-A)

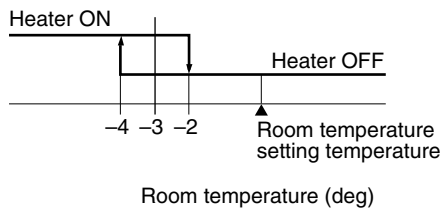

■ Heat exchanger temperature (THi-R1, R2)

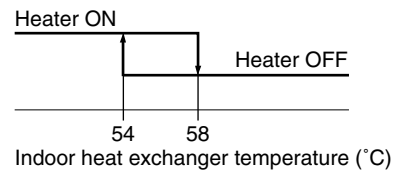

Notes (1) When the conditions for thermostat ON and 52H-ON are satisfied, → 52H-ON

(2) When the conditions for thermostat OFF or 52H-OFF are satisfied, → 52H-OFF

Additionally, when the indoor blower stops, during the compressor stop and the control of the temperature of the outlet pipe and the high pressure control, and the current safe control, even if above-mentioned conditions for 52H-ON are satisfied, 52H are still turned OFF.

b) When the heater became no energizing from energizing, even if indoor blower (FMI) satisfies the stop (stopping operation by remote control or abnormal stop) condition, in order to take the remaining heat of the heater, none but after making FMI operate in Lo for 40 seconds it can be made stop.

6. FILTER sign

a) If cumulative operating time (the time the Run/Stop switch is ON) reaches 600 hours, "FILTER CLEANING" is displayed in the remote controller.

Note (1) If jumper wire J1 (SW7-1) on the indoor PCB is disconnected, this function is deactivated.

b) The functions of the remote controller can be set to display 180 hours, 600 hours, 1,000 hours, 1,000 hours & Forced Stop, and no display.

c) If it is set on 1,000 hours & Forced Stop, after 1,000 hours of operation, there is a forced stop after an additional 24 hours have passed. (If the filter sign is not reset, operation cannot be resumed.) Resetting from the remote controller is possible at all times (while running, while stopped and before time up) when a filter reset signal is received. It is also reset when the power is turned OFF.

7. Auto swing control (FDT, FDTW, FDTQ, FDTS, FDE and FDK only)

a) Louver Control

1) When the air conditioner is operating, press the "LOUVER" switch to move the swing louvers. "AUTO → " is displayed for 3 seconds, then the swing louvers begin moving up and down continuously.

2) When you desire to fix the position of the swing louvers, press the "LOUVER" switch while the swing louvers are moving, and 4 stop positions will be displayed one at a time in 1 second intervals. When the position you desire to louvers to stop at is displayed, press the "LOUVER" switch again. The display will

- stop message (ex. "STOP 1-  ") will be displayed for 3 seconds and the swing louvers will stop.
- 3) Louver operation when the power to the 4-position louver controller is turned on.
When the power is turned on, the louvers automatically swing 1 (2) time (without remotecontroller operation). This operation inputs the position of the louver motor (LM) in the microcomputer so it can confirm the louver position.

Notes (1) The louver position LCD displays the swing operation for 10 seconds when the "LOUVER" switch is turned ON. After that, "AUTO  " is displayed for 3 seconds in the LCD.
(2) Values in () show in cases other than the FDT, FDE and FDK 22~56 models.

b) Louver auto horizontal set during heating

The louvers are in the horizontal position regardless of whether the auto swing switch is operated (auto swing or louver stop) while "  (Heating Preparation)" is displayed (during hot start and when the heating thermostat is OFF). (This is to prevent cold drafts), and the display that was in the louver position display LCD before this control was activated continues.
If the "Heating Preparation" display goes off, both the louvers and the LCD display return to their original setting.

c) Louver free stop control

If "IN MOTION (louver free stop)" is set in the remote controller's function settings, the louver motor stops if there is a stop signal from the remote control unit and the stop position is stored in memory. Also, if there is an auto swing signal from the remote control unit, auto swing control starts from the position the louvers were in before being stopped.

8. Simple and clean mechanism control (for FDKA28~45 model only)

When OFF state of limit SW (open) is detected for one second while operating, operating is stopped.

9. Condensate pump motor (DM) control (Only FDT, FDTW, FDTQ, FDTS, FDR, FDQM, FDUM models)

a) Drain motor is started no sooner than the compressor is turned ON during cooling or dehumidifying operation. The drain motor continues to operate for 5 minutes after the stop of unit operation, stop with the error stop, thermostat stop and at switching from cooling or dehumidifying operation to blowing or heating operation. When there is any unit subjected to oil return control, the drain motor is operated for 5 minutes at such occasion.

Note (1) The drain motor is turned on at the same time as heating operation, when the humidifying and draining are synchronized (J8 opening). (Do not synchronize with ON/OFF of the compressor.)

b) Overflow detection is always operable by means of the float switch regardless of operation modes. If the overflow is detected (or when the float switch is disconnected or its wire is broken), operation is stopped with the error stopped. If the overflow is detected while the drain motor is stopped, the drain motor is operated for 3 minutes and then the overflow detection is performed to judge whether it is normal or not.

	Indoor unit operation mode				
	OFF ⁽¹⁾	COOL	DRY	FAN ⁽²⁾	HEAT
During compressor ON		Control A			
During compressor OFF		Control B			

Notes (1) Including OFF and error stop during COOL, DRY, FAN and HEAT.

(2) Including "FAN" operation due to unmatch of operation mode.

(1)Control A

- 1) If the float switch senses draining, it performs an abnormal stop (E9 is displayed) and operates the drain pump. after 3 minutes pass, the float switch is checked and if it is normal, drain pump operation is stopped. It also preserves an abnormal stop state.
- 2) If the float switch continues to detect draining, the drain pump continues to operate and the float switch operates while draining is detected.

(2)Control B

If the float switch detects draining, it turns the drain motor on for 3 minutes, then 10 seconds after the drain motor goes OFF, it checks the float switch. If it is normal, a normal stop is performed and if it is abnormal, E9 is displayed and the drain motor goes ON. (It remains ON while draining is detected.)

10. Frost prevention during cooling, dehumidifying

In order to prevent frost during cooling and dehumidifying, 9 minutes after compressor operation starts, the temperature sensed the indoor heat exchanger (sensed by Thi-R1, R2) is checked and the following controls are carried out.

a) Required frequency down control

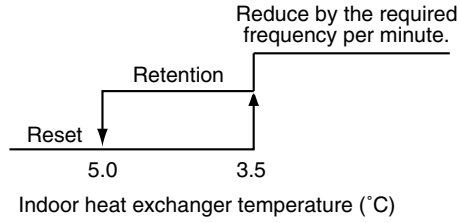

- Notes (1) Through required frequency down control, if the required frequency is not reached, fuzzy control is carried out.
 (2) If the temperature at Th_i-R1 and R2 becomes 5.0°C continuously for 6 minutes, this control is terminated.

b) Thermostat OFF control

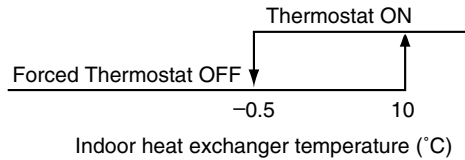

- Notes (1) After the thermostat goes ON, forced thermostat OFF does not operate for a period of 9 minutes.
 (2) Forced thermostat OFF operates if the temperature at Th_i-R1 or R2 becomes -0.5°C or lower.

11. Indoor expansion valve control

a) Cooling superheat control

1 minute after the thermostat switches ON during a cooling or dehumidifying operation, superheating is maintained at a suitable level by expansion valve aperture control based on the difference between the indoor heat exchanger's inlet and outlet temperatures (detected by Th_i-R3 and Th_i-R1 or R2), and the amount of deviation from the superheat setting value. Cooling superheat control ends when operation stops, or when the thermostat switches OFF.

b) Heating supercool control

Opening of expansion valve is controlled and the supercooling is kept proper by using the error between the temperature difference of indoor air heat exchanger (detected with Th_i-R1 and Th_i-R2) and the sub-cooling setting value while heating, and after 1 minute since thermostat is turned ON and after 2 minutes since defrosting ends. This process ends when operation stops, and thermostat is turned OFF, and defrosting starts.

c) Heating paused unit refrigerant control

In order to control the amount of refrigerant collected in a heating paused unit during outdoor unit heating operation, paused unit refrigerant control occurs individually at the paused units that satisfy the following conditions.

(1) Start conditions

- ① After thermostat switches OFF
 - ② After heating → stop, or stop → blow switching
 - ③ After outdoor unit heating begins during a stop (including error stops)
 - ④ After electronic expansion valve full-closed control
 - ⑤ After receiving a "refrigerant recovery" signal from the outdoor unit
- } After 12 hours elapses

(2) Control description

The electronic expansion valve opens to the setting aperture for 1 minutes.

(3) Control termination conditions.

- ① When the outdoor unit stops
- ② When a defrost operation begins
- ③ When the thermostat switches ON
- ④ When the indoor heat exchanger sensor (Th_i-R1 or Th_i-R2) detects a temperature exceeding 55°C.

12. High ceiling control

In the case of indoor units installed in high ceilings, air flow mode control can be changed by using DIP switch SW9-4 on the indoor PCB, or by using the remote controller indoor function setting (see page 387).

DIP SW	SW9-4 OFF (Normal Control)	SW9-4 ON (High Ceiling Control)
Air Flow Mode	Hi, Me, Lo	UHi, Hi, Me

- Notes (1) When the unit is shipped, SW9-4 is turned OFF.
 (2) If SW9-4 is ON, the fan operates in Me even during hot start and when the heating thermostat is OFF.

13. Thermistor (Return air, heat exchanger) disconnected
- a) Return air temperature thermistor
If the temperature detected by the thermistor is -20°C or lower continuously for 5 seconds, an abnormal stop is performed.
 - b) Indoor heat exchanger temperature thermistor
If the temperature detected by the thermistor (Thi-R1, R2 or R3) 2 minutes ~ 2 minutes 20 seconds after the thermostat goes ON and the compressor starts is -40°C or lower continuously for 5 seconds, or if the temperature is -40°C or lower continuously for 5 seconds within 10 seconds after the power is turned on, an abnormal stop is performed.

14. Indoor fan abnormal [FDTA112, 140 or FDKA22 ~ 56 types only]
- If the indoor unit fan speed is less than 200 rpm continuously for 30 seconds after a n indoor unit fan run command is output, it stops for 2 seconds. After 2 seconds, it restarts, but if this operation is repeated 4 times within 60 seconds, an abnormal stop is performed.

15. Control for operating permission, prohibition, and coin timer
- Whether air conditioner operation is enabled or not is controlled by opening the jumper on indoor control PCB and external input to CnT.
(Use when it is controlled to be able to use air conditioner and not to operate it according to signal etc. of coin timer on the market)

- a) It changes into the operating permission and the prohibition mode by opening the jumper on the indoor control PCB.

Jumper(J2)short circuit	Jumper(J2)open
It is possible to operate normally. (Ship it.) CnT ①-⑥ ON :operating OFF:stop	Operating permission and prohibition mode CnT ①-⑥ ON :operating permission OFF:operating prohibition mode

- b) When the input to CnT is ON (operating permission)
 - 1) The air conditioner corresponds to the signal from the remote control and it is possible to do the operations and the stop, etc.
(When the center mode is set, it is possible to operate it only from the center.)
 - 2) The states of air conditioner when the input to CnT becoming ON from OFF are switched between operating and stop by the state of SW5-3 on the indoor control PCB.

SW5-3 · OFF	SW5-3 · ON
It starts according to the signal of item 1) like the air conditioner stop. (Ship it)	It depends on the signal of item 1) after the air conditioner begins to operate. (Local setting)

Note (1) The operation to external is output.

- c) When the input to CnT is OFF (operating prohibition)
 - 1) It is impossible to do the operations of operating and the stop to air conditioner through the corresponding signal from the remote control.
 - 2) When the input to CnT changes into OFF from ON, air conditioner stops.
- d) It becomes item a) when making operating permission/prohibiting active through the indoor function set by remote control.

16. External control (remote display) / control of input signal
- Make sure to connect the standard remote control unit. Control of input signal is not available without the standard remote control unit.

- a) External control (remote display) output
Following output connectors (CNT) are provided on the printed circuit board of indoor unit.
 - 1) Operation output: Power to engage DC 12V relay (provided by the customer) is outputted during operation.
 - 2) Heating output: Power to engage DC 12V relay (provided by the customer) is outputted during the heating operation.
 - 3) Thermistor ON output: Power to engage DC 12V relay (provided by the customer) is outputted while the thermistor is operating.
 - 4) Error output: When any error occurs, the power to engage DC 12V relay (provided by the customer) is outputted.

Remark: Connect the remote monitoring kit and take out each non-voltage contact.

b) Control of input signal

Control of input signal (switch input, timer input) connectors (CnT) are provided on the control circuit board of the indoor unit. However, when the operation of air conditioner is under the Center Mode, the remote control by CnT is invalid.

(1) If the factory settings (SW5-3 on the PCB is OFF) are set, or "LEVEL INPUT" is selected in the remote controller's indoor unit settings.

- 1) Input signal to CnT OFF → ON ----- Air conditioner ON
- 2) Input signal to CnT ON → OFF ----- Air conditioner OFF

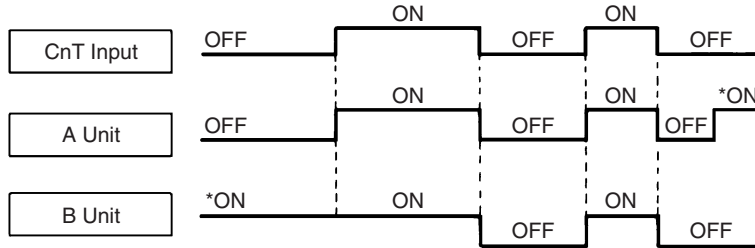

- Note (1) The ON with the * mark indicates an ON operation using the remote control unit switch, etc.
 (2) When SW5-3 on the PCB of indoor unit is turned on at the field or "PULSE INPUT" is selected in the remote controller's indoor unit settings. Input signal to CnT becomes valid at OFF → ON only and the motion of air conditioner [ON/OFF] is inverted.

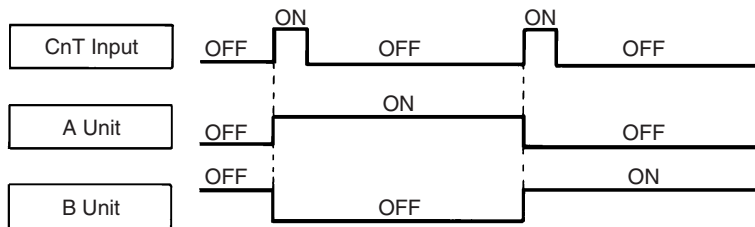

17. Operation/error output

The following signal is output to CnT connector on indoor control PCB.

(Use the remote monitoring kit for the DC12v relay.)

- a) Operation output [XR1] (Operation : ON, stop and abnormal stop : OFF)
- b) Error output [XR4] (Error : ON)
- c) Thermistor output [XR3] (Indoor unit thermistor ON)
- d) Heating output [XR2] (Heating operation ON)

Output relay operates

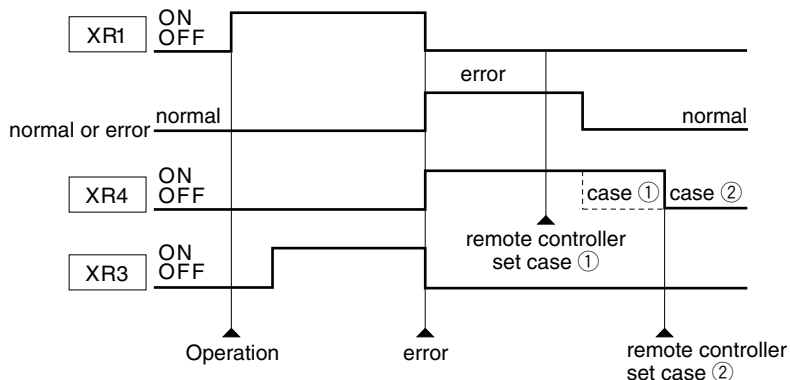

18. Multiple units control-simultaneous control of 16 unit with one remote controller

a) Function

Multiple units (even of outdoor different systems, 16 units maximum) can be simultaneously controlled by using a remote controller. The remote controller is used to set the "operation mode", and all the unit can be operated and stopped. Thermostat and protective functions of each unit functions independently.

Note (1) When part of the group gets out of order (the protective device operates), the relevant unit comes to an abnormal stop, but other normal units keep operating.

b) Wiring Procedures

- (1) Lay power cable of each unit and signal wire as usual. (Remove the remote control switches from all units excluding only one unit.) Lay wiring for the remote controller separately from power cable and wires for all other electrical equipment.
- (2) Arrange the terminal block (X, Y, Z) of the remote controller as shown below for the simultaneous control, and lay cross over in each indoor unit.

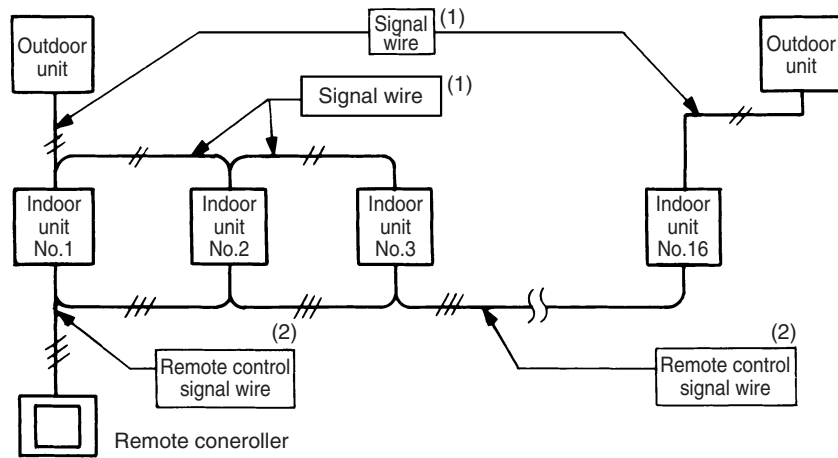

- Notes
- (1) The overall length of the signal wire shall be less than 1000m.
 - (2) The length of remote control signal wire and crossover for remote controller between room shall be less than 600m.