

Always read before installation.

AISIN GHP Aisin INDOOR UNITS
INSTALLATION AND MAINTENANCE INSTRUCTIONS
[Model] Wall-mounted Type

■ **Applicable models**

AXAP22PAD	AXAP45PAD
AXAP28PAD	AXAP56PAD
AXAP36PAD	AXAP71PAD

■ **Important reminder**

- THOROUGHLY READ THESE INSTRUCTIONS BEFORE STARTING THE INSTALLATION AND FOLLOW ALL PROCEDURES DESCRIBED WITHIN.
- KEEP THIS MANUAL IN A HANDY PLACE FOR FUTURE REFERENCE.

After installation, always use the checklist to perform a final inspection.

EC Declaration of Conformity

Dichiarazione di Conformità CE



WE: TECNOCASA S.p.A.
La: VIA MANZONI 17
60025 Loreto (AN)
ITALY

Declare under its own responsibility that the units:

Dichiara sotto la sua Responsabilità che le Unità interne:

Type:

Tipo:

AXJP22A2D	AXJP28A2D	AXJP36A2D	AXJP45A2D	AXJP56A2D	
AXFP22AVD	AXFP28AVD	AXFP36AVD	AXFP45AVD	AXFP56AVD	AXFP90AVD
AXFP112 AVD	AXFP140AVD				
AXMP45P7D	AXMP56P7D	AXMP71P7D	AXMP90P7D	AXMP112P7D	AXMP140P7D
AXMP224P7D	AXMP280P7D				
AXAP22PAD	AXAP28PAD	AXAP36PAD	AXAP45PAD	AXAP56PAD	AXAP71PAD
AXLP22P2D	AXLP28P2D	AXLP36P2D	AXLP45P2D	AXLP56P2D	AXLP71P2D
AXCP22AVD	AXCP28AVD	AXCP36AVD	AXCP45AVD	AXCP56AVD	AXCP71AVD
AXCP90AVD	AXCP112AVD	AXCP140AVD			
AXSP22P7D	AXSP28P7D	AXSP36P7D	AXSP45P7D	AXSP56P7D	AXSP71P7D
AXSP90P7D	AXSP112P7D	AXSP140P7D			
AXHP36AVD	AXHP71AVD	AXHP112AVD			
AXDP22P7D	AXDP28P7D				

Brand: AISIN SEIKI CO.LTD

Marca:

Serial number: See the number on the unit label

N° di serie: vedere il numero sulla targa dati

Year of production: See the year on the unit label

Anno di produzione: vedere il numero sulla targa dati

Comply with following Directives of the council of the European Community:

E' conforme alle seguenti Direttive della Comunità Europea:

- 1) Directive 98/37/CE and subsequent modification, relating to machinery
Direttiva 98/37/CE e successive modifiche, relativa alle Macchine
- 2) Directive 2006/95/CE and subsequent modification, relating to low voltage LVD
Direttiva 2006/95/CE e successive modifiche, relativa alla Bassa Tensione LVD
- 3) Directive 2004/108/CE and subsequent modification, relating to electromagnetic compatibility EMC
Direttiva 2004/108/CE e successive modifiche, relative alla compatibilità elettromagnetica EMC

Date: Loreto 01 Aprile 2014

Name:

TECNOCASA S.p.A.

Position:

Mr.Mogliani Graziano

Signature:

Legal Representative

TECNOCASA S.p.A.

Via Manzoni, 17
60025 LORETO - AN
Tel. 071 977805 - Fax 071 976481
Part. IVA 01051530424

CONTENTS

1. SAFETY PRECAUTIONS.....1
 2. BEFORE INSTALLATION2
 3. SELECTING INSTALLATION SITE.....5
 4. INDOOR UNIT INSTALLATION6
 5. REFRIGERANT PIPING WORK9
 6. DRAIN PIPING WORK12
 7. ELECTRIC WIRING WORK13
 8. HOW TO CONNECT WIRINGS AND WIRING EXAMPLE14
 9. FIELD SETTINGS19
 10. TEST OPERATION20

1. SAFETY PRECAUTIONS

Please read these "SAFETY PRECAUTIONS" carefully before installing air conditioning unit and be sure to install it correctly.

After completing installation, conduct a trial operation to check for faults and explain to the customer how to operate the air conditioner and take care of it with the aid of the operation manual. Ask the customer to store the installation manual along with the operation manual for future reference.

This air conditioner comes under the term "appliances not accessible to the general public".

Safety Precaution

This unit is a class A product. In a domestic environment this product may cause radio interference in which case the user may be required to take adequate measures.

Meaning of WARNING and CAUTION notices



WARNINGFailure to follow these instructions properly may result in personal injury or loss of life.



CAUTIONFailure to observe these instructions properly may result in property damage or personal injury, which may be serious depending on the circumstances.



WARNING

- Ask your dealer or qualified personnel to carry out installation work.
 Do not attempt to install the air conditioner yourself. Improper installation may result in water leakage, electric shocks or fire.
- Install the air conditioner in accordance with the instructions in this installation manual.
 Improper installation may result in water leakage, electric shocks or fire.
- Consult your local dealer regarding what to do in case of refrigerant leakage. When the air conditioner is to be installed in a small room, it is necessary to take proper measures so that the amount of any leaked refrigerant does not exceed the concentration limit in the event of a leakage. Otherwise, this may lead to an accident due to oxygen depletion.
- Be sure to use only the specified accessories and parts for installation work.
 Failure to use the specified parts may result in the unit falling, water leakage, electric shocks or fire.
- Install the air conditioner on a foundation strong enough to withstand the weight of the unit.
 A foundation of insufficient strength may result in the equipment falling and causing injury.
- Carry out the specified installation work after taking into account strong winds, typhoons or earthquakes.
 Failure to do so during installation work may result in the unit falling and causing accidents.

- Make sure that a separate power supply circuit is provided for this unit and that all electrical work is carried out by qualified personnel according to local laws and regulations and this installation manual. An insufficient power supply capacity or improper electrical construction may lead to electric shocks or fire.
- Make sure that all wiring is secured, the specified wires are used, and that there is no strain on the terminal connections or wires. Improper connections or securing of wires may result in abnormal heat build-up or fire.
- When wiring the power supply and connecting the wiring between the indoor and outdoor units, position the wires so that the control box cover can be securely fastened. Improper positioning of the control box cover may result in electric shocks, fire or the terminals overheating.
- If refrigerant gas leaks during installation, ventilate the area immediately. Toxic gas may be produced if the refrigerant comes into contact with fire. • After completing installation, check for refrigerant gas leakage. Toxic gas may be produced if the refrigerant gas leaks into the room and comes into contact with a source of fire, such as a fan heater, stove or cooker.
- Be sure to switch off the unit before touching any electrical parts.
- Do not directly touch refrigerant that has leaked from refrigerant pipes or other areas, as there is a danger of frostbite. • Be sure to earth the air conditioner. Do not earth the unit to a utility pipe, lightning conductor or telephone earth lead. Imperfect earthing may result in electric shocks or fire. A high surge current from lightning or other sources may cause damage to the air conditioner.
- Be sure to install an earth leakage breaker. Failure to install an earth leakage breaker may result in electric shocks or fire.

CAUTION

- While following the instructions in this installation manual, install drain piping to ensure proper drainage and insulate piping to prevent condensation. Improper drain piping may result in indoor water leakage and property damage.
- Install the indoor and outdoor units, power cord and connecting wires at least 1 meter away from televisions or radios to prevent picture interference and noise. (Depending on the incoming signal strength, a distance of 1 meter may not be sufficient to eliminate noise.)
- Remote controller (wireless kit) transmitting distance can be shorter than expected in rooms with electronic fluorescent lamps (inverter or rapid start types). Install the indoor unit as far away from fluorescent lamps as possible.
- Do not install the air conditioner in the following locations:
 1. Where there is a high concentration of mineral oil spray or vapour (e.g. a kitchen). Plastic parts will deteriorate, parts may fall off and water leakage could result.
 2. Where corrosive gas, such as sulphurous acid gas, is produced. Corroding of copper pipes or soldered parts may result in refrigerant leakage.
 3. Near machinery emitting electromagnetic radiation. Electromagnetic radiation may disturb the operation of the control system and result in a malfunction of the unit.
 4. Where flammable gas may leak, where there is carbon fibre or ignitable dust suspensions in the air, or where volatile flammables such as paint thinner or gasoline are handled. Operating the unit in such conditions may result in fire.
- The air conditioner is not intended for use in a potentially explosive atmosphere.

2. BEFORE INSTALLATION

Do not exert pressure on the resin parts when opening the unit or when moving it after opening. Be sure to check the type of R410A refrigerant to be used before doing any work. (Using an incorrect refrigerant will prevent normal operation of the unit.)





- When opening the unit or moving it after opening, be sure to lift it by holding on to the lifting lugs without exerting any pressure on other parts, especially, drain piping, and other resin parts. • Decide upon a line of transport.
- Leave the unit inside its packaging while moving, until reaching the installation site. Use a sling of soft material, where unpacking is unavoidable or protective plates together with a rope when lifting, to avoid damage or scratches to the unit.
- **Especially, do not unfasten packing case(top) guarding the control box until suspending the unit.** • Refer to the installation manual of the outdoor unit for items not described in this manual. • Do not dispose of any parts necessary for installation until the installation is complete.



2-1 PRECAUTIONS

- Be sure to read this manual before installing the indoor unit.
- When selecting installation site, refer to the installation pattern.
- This unit, both indoor and outdoor, is suitable for installation in a commercial and light industrial environment. If installed as a household appliance it could cause electromagnetic interference.
- Entrust installation to the place of purchase or a qualified serviceman. Improper installation could lead to leaks and, in worse cases, electric shock or fire.
- Use only parts provided with the unit or parts satisfying required specifications. Unspecified parts could cause the unit to fall out of place, or could lead to leaks and, in worse cases, electric shock or fire.
- Do not install or operate the unit in rooms mentioned below.
 - **Laden with mineral oil, or filled with oil vapor or spray like in kitchens. (Plastic parts may deteriorate which could eventually cause the unit to fall out of place, or could lead to leaks.)**
 - **Where corrosive gas like sulfurous gas exists. (Copper tubing and brazed spots may corrode, which could eventually lead to refrigerant leaks.)**
 - **Where volatile flammable gas like thinner or gasoline is used.**
 - **Where exposed to combustible gases and where volatile flammable gas like thinner or gasoline is used. (Gas in the vicinity of the unit could ignite.)**
 - **Where machines can generate electromagnetic waves. (Control system may malfunction.)**
 - **Where the air contains high levels of salt such as that near the ocean and where voltage fluctuates greatly such as that in factories. Also in vehicles or vessels.**

2-2 ACCESSORIES

Check the following accessories are included with your unit.

Name	(1) Installation panel	(2) Attachment screws for the installation panel	(3) Paper pattern for installation	(4) Insulating tape
Quantity	1 set	8 pcs. → AXAP22,28,36 type 9 pcs. → AXAP45,56,71 type	1 pc.	1 pc.
Shape		 M4 × 25L		

Name	(5) Clamp	(6) Securing screws	(Other) • Operation manual • Installation manual
Quantity	1 large 3 small	2 pcs.	
Shape		 M4 × 12L	

2-3 OPTIONAL ACCESSORIES

- These are two types of remote controllers: wired and wireless. Select a remote controller according to customer request and install in an appropriate place.

Remote controller type		Model
Wired type		BRC1C517 · *ABRC1D528 · *BRC1E51A7
Wireless type	Heat pump type	BRC7E618
	Cooling only type	BRC7E61

* Refer to installation manual attached to the remote controller.

NOTE

- If the customer wishes to use a remote controller that is not listed above, select a suitable remote controller after consulting catalogs and technical materials.

FOR THE FOLLOWING ITEMS, TAKE SPECIAL CARE DURING CONSTRUCTION AND CHECK AFTER INSTALLATION IS FINISHED.

a. Items to be checked after completion of work

Items to be checked	If not properly done, what is likely to occur	Check
Are the indoor and outdoor unit fixed firmly?	The units may drop, vibrate or make noise.	
Is the outdoor unit fully installed?	The unit may malfunction or the components burn out.	
Is the gas leak test finished?	It may result in insufficient cooling.	
Is the unit fully insulated?	Condensate water may drip.	
Does drainage flow smoothly?	Condensate water may drip.	
Does the power supply voltage correspond to that shown on the name plate?	The unit may malfunction or the components burn out.	
Are wiring and piping correct?	The unit may malfunction or the components burn out.	
Is the unit safely grounded?	Dangerous at electric leakage.	
Is wiring size according to specifications?	The unit may malfunction or the components burn out.	
Is something blocking the air outlet or inlet of either the indoor or outdoor units?	It may result in insufficient cooling.	
Are refrigerant piping length and additional refrigerant charge noted down?	The refrigerant charge in the system is not clear.	

b. Items to be checked at time of delivery

Also review the "SAFETY PRECAUTIONS"

Items to be checked	Check
Are the control box cover, air filter, suction grille attached?	
Did you explain about operations while showing the instruction manual to your customer?	
Did you hand the instruction manual over to your customer?	

c. Points for explanation about operations

The items with **⚠** WARNING and **⚠** CAUTION marks in the instruction manual are the items pertaining to possibilities for bodily injury and material damage in addition to the general usage of the product. Accordingly, it is necessary that you make a full explanation about the described contents and also ask your customers to read the instruction manual.

2-4 NOTE TO THE INSTALLER

Be sure to instruct customers how to properly operate the unit (especially cleaning filters, operating different functions, and adjusting the temperature) by having them carry out operations themselves while looking at the manual.

3. SELECTING INSTALLATION SITE

(1) Select an installation site where the following conditions are fulfilled and that meets with your customer's approval.

- In the upper space (including the back of the ceiling) of the indoor unit where there is no possible dripping of water from the refrigerant pipe, drain pipe, water pipe, etc. •

Where the wall is strong enough to bear the indoor unit weight.

- Where sufficient clearance for installation and maintenance can be ensured.

(Refer to Fig. 1 and Fig. 2)

- Where optimum air distribution can be ensured. •

Where nothing blocks the air passage.

- Where condensate can be properly drained.

- Where the wall is not significantly tilted. • Where

not exposed to combustible gases.

- Where pipe between indoor and outdoor units is possible within the allowable limit.

(Refer to the installation manual of the outdoor unit.)

- Install the indoor and outdoor units, power cable and transmission wiring, at least 1 m from TVs and radios, to prevent distorted pictures and static. (Depending on the type and source of the electrical waves, static may be heard even when more than 1 m away.)

- Install the indoor unit no less than 2.5 m above the floor. Where unavoidably lower, take what measures are necessary to keep hands out of the air inlet.

- Where the cool (warm) air reaches all across the room.

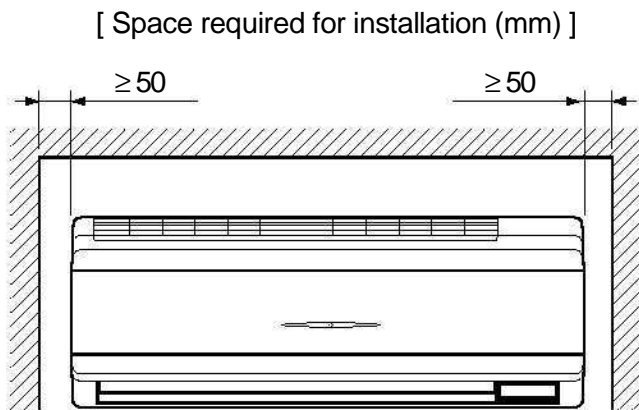

Fig. 1

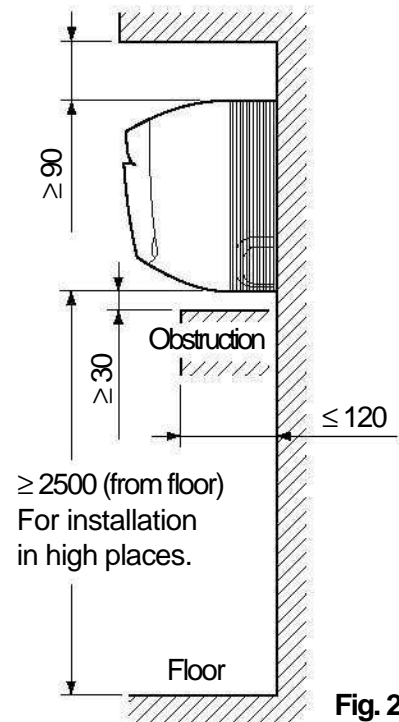

Fig. 2

⚠ CAUTION

- The indoor and outdoor units and the power supply wiring and remote controller cord must be installed at least 1m away from any televisions or radios. This is to prevent interference with picture and sound reception. (Interference may occur even at 1m away depending on the reception quality.)
- If installing the wireless kit, the distance of the signal sent from the remote controller might be shorter if there are fluorescent lights which are electrically started (such as with inverters, rapid starters, etc.) in the room. The indoor unit should be installed as far away from fluorescent lights as possible.

(2) Consider whether the place where the unit will be installed can support the full weight of the unit, and reinforce it with boards and beams, etc. if needed before proceeding with the installation. Also, reinforce the place to prevent vibration and noise before installing.

(The installation pitch can be found on the paper pattern for installation (3), so refer to it when considering the necessity for reinforcing the location.)

(3) The indoor unit may not be directly installed on the wall. Use the attached installation panel (1) before installing the unit.

4. INDOOR UNIT INSTALLATION

- Use only accessories and parts which are of the designated specification when installing.

⚠ CAUTION

- Install so that the unit does not tilt to either side or forward.
- Do not hold the unit by the horizontal flaps when lifting it. (This may damage the horizontal flaps.)

(1) Open the piping through-hole.

- The refrigerant pipe and drain pipe can be passed out in one of 6 directions: left, bottom-left, back-left, right, bottom-right, and back-right. **(Refer to Fig. 3)**
- Using the paper pattern for installation (3), choose where to pass the piping out and open a through-hole ($\phi 80$) in the wall.
Open the hole so that there is a downward slope for the drain piping. (See " 6.DRAIN PIPING WORK ")

(2) Remove the installation panel (1) from the unit and attach to the wall.

(The installation panel is temporarily attached to the unit with screw. (In case of 22-36 type)
(Refer to Fig. 3)

- (a) Check the location for the hole using the included paper pattern for installation (3).
 - Choose a location so that there is at least a 90 mm gap between the ceiling and the main unit.
- (b) Temporarily attach the installation panel (1) at the temporary-securing position on the paper pattern for installation (3) and use a level to make sure the drain hose is either level or tilted slightly downward.
- (c) Secure the installation panel (1) to the wall using either screws or bolts.
 - If using the attachment screws for the installation panel (2), attach using at least 4 screws on either side (for a total of 8 screws (22-36 type), 9 screws (45-71 type)) of the recommended installation cleat position on the included paper pattern for installation (3).
 - If using bolts, attach using a M8 - M10 bolt (for a total of 2 bolts) on either side. • If dealing with concrete, use commercially available foundation bolts (M8 - M10).

(3) If using the left, bottom-left, right, or bottom-right positions for the piping, cut out the through-hole for the piping in the front grill. (Refer to Fig. 4)

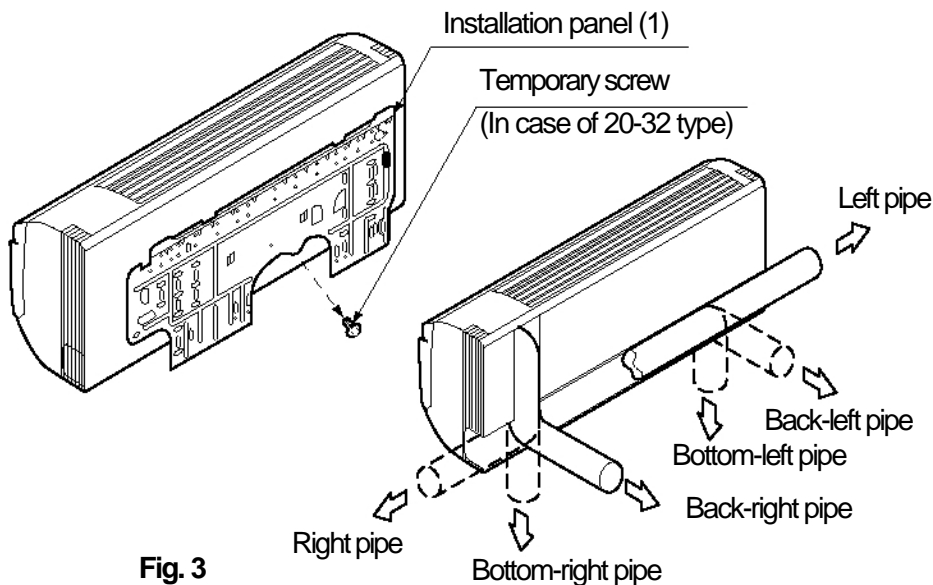

Fig. 3

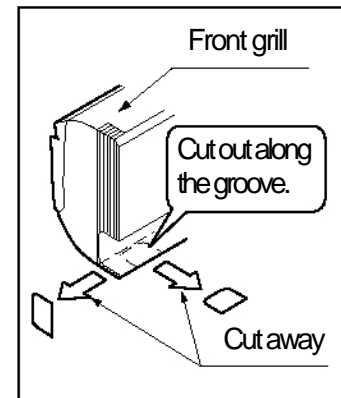

Fig. 4

(4) Remove the front panel and the service lid. (Refer to Fig. 5)

< How to remove the front panel and service lid > (1) Open

the front panel to the point where it stops.

(2) Push the axes on either side of the front panel towards the center of the main unit and remove. (You can also remove it by sliding the front panel either to the left or right and pulling it forward.)

(3) Remove the screw from the service lid and pull the handle forward.

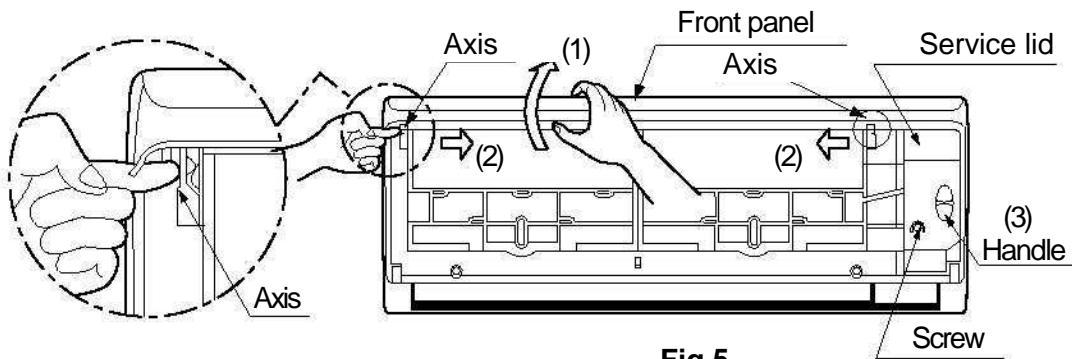

Fig.5

(5) Point the pipe in the direction it will be passed out.

For right, bottom-right, and back-right piping (Refer to Fig. 6)

- Wrap the drain hose and the refrigerant piping together with the insulating tape (4) so that the drain hose is below the refrigerant piping.

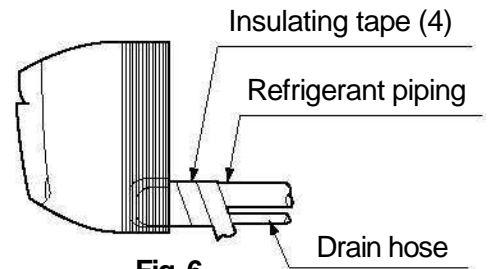

Fig. 6

For left, bottom-left, and left-back piping

- Remove the front grill. (Refer to Fig. 7)

< How to remove the front grill >

Remove the front grill as described below when securing the indoor unit with screws or when attaching Optional Accessories (wireless remote controller, adapter PC board, etc.).

- (1) Remove the front panel.
- (2) Remove the screws (2 places in case of AXAP22,28,36 type/3 places in case of AXAP45,56,71 type) securing the front grill.
- (3) Remove the tabs (3 places) securing the front grill by pushing them in the direction of the arrows.
- (4) Making sure not to catch the horizontal flaps, remove the front grill by pulling in the direction of the arrow.

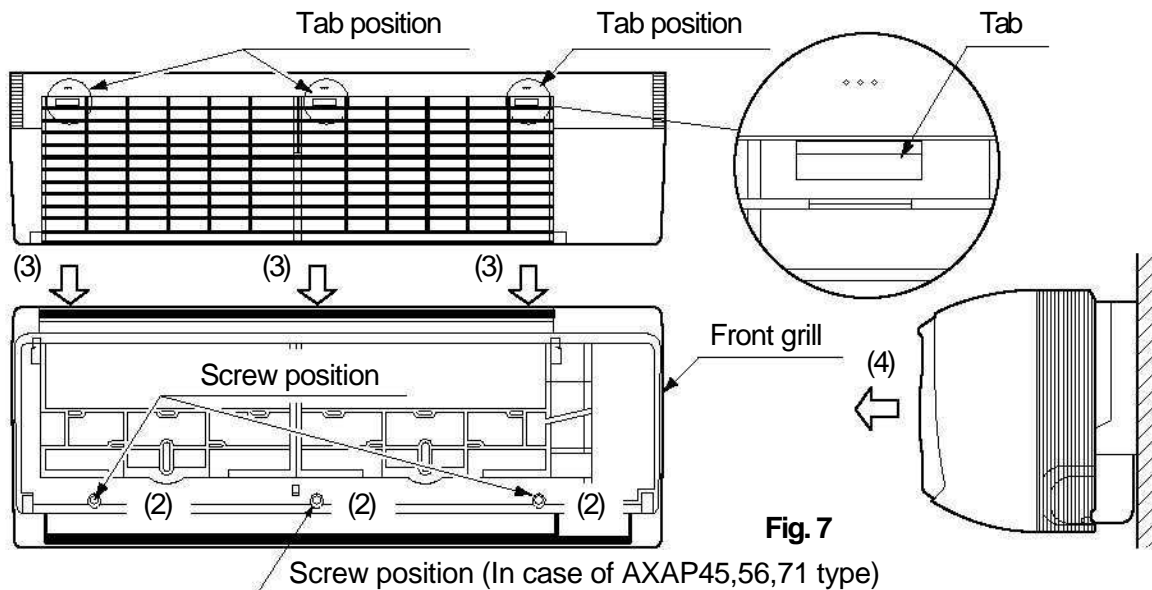

Fig. 7

- Remove the drain plug, the insulation tubing, and the drain hose from the drain pan and replace. (Refer to Fig. 8)
- Connect the local refrigerant piping ahead of time, matching it to the liquid pipe and gas pipe marks engraved on the installation panel (1).

< Replacing the drain hose and drain plug >

- (1) Remove the drain plug and insulation tubing.
- (2) Remove the drain hose and replace onto the left side.
- (3) Replace the drain plug and the insulation tubing onto the right side.

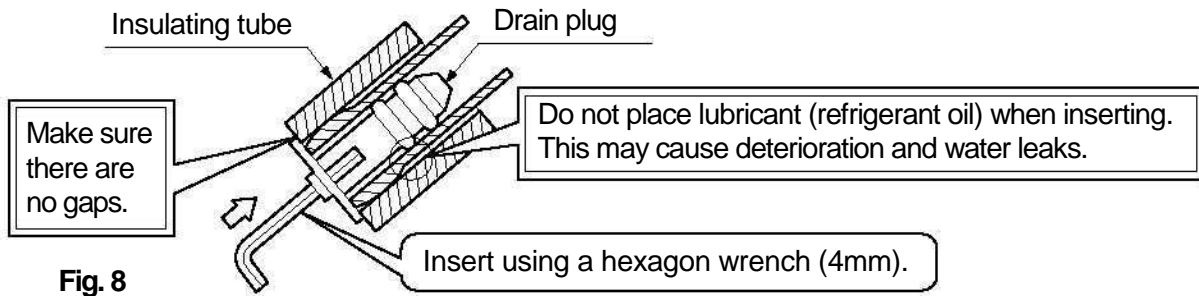

Fig. 8

(6) Hook the indoor unit onto the installation panel. (Refer to Fig. 9)

- Placing buffering material between the wall and the indoor unit at this time will make work easier.

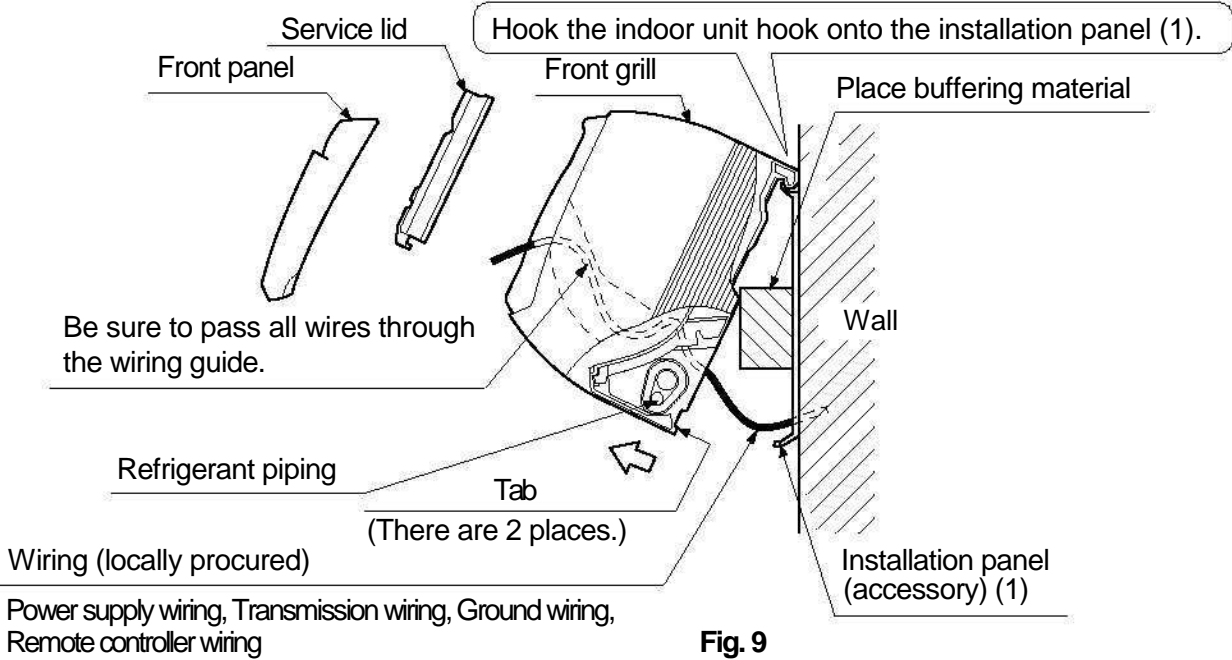

Fig. 9

For right, bottom-right, and back-right piping

- Pass the drain hose and the refrigerant piping to the wall.

(7) Pass power supply wiring, transmission wiring, ground wiring, and remote controller wiring through the wiring guide in through the back of the indoor unit and to the front.

(8) Connect the piping. (See "5.REFRIGERANT PIPING WORK" and Fig. 10)

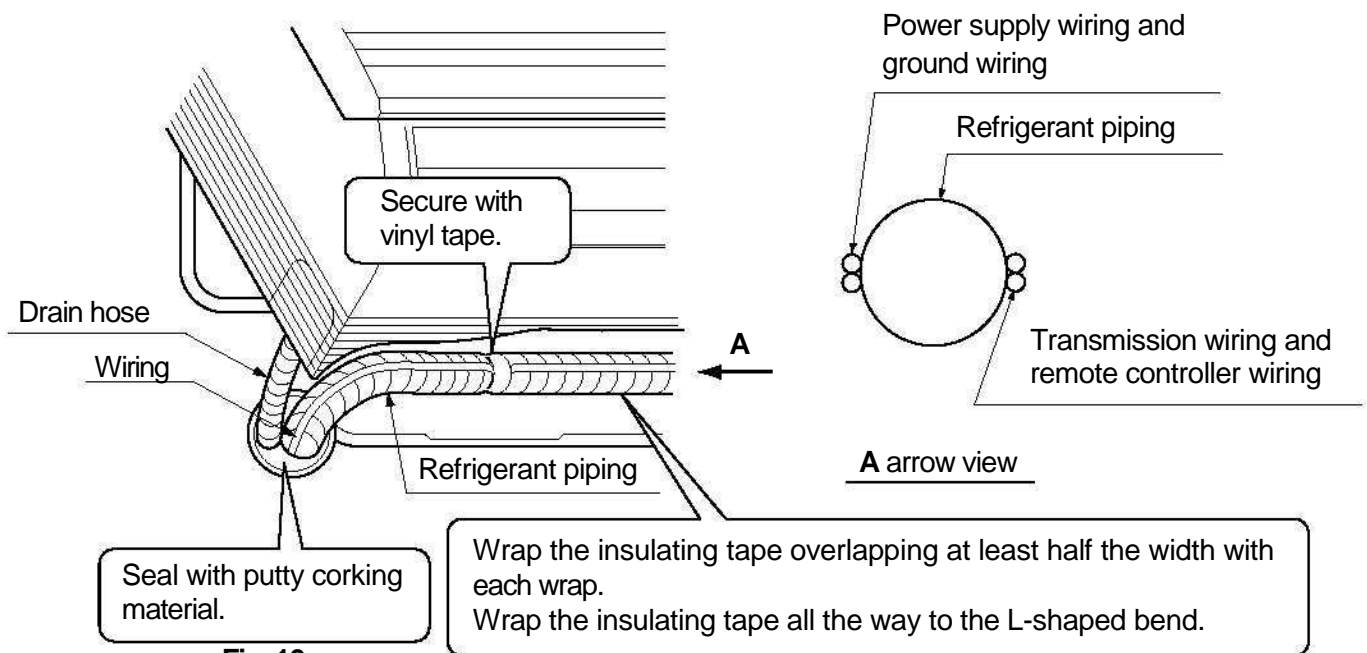

Fig. 10

- To avoid the influence of noise from the power supply line on the transmission wiring and the remote controller wiring, these wirings must be kept as far as possible from the power/ground wirings. As shown in the figure, keep the power supply wiring and the ground wiring together. Keep the transmission and remote controller wirings together and route them maintaining a good distance from the power supply/ground wirings (that is, on the other side of the power supply/ground wirings). Then, fix them securely on the refrigerant pipe.
- Seal the piping through-hole with putty corking material.

(9) Push on both bottom edges of the indoor unit using both hands and hook the tab on the back of the indoor unit onto the installation panel (1). (Refer to Fig. 9) • At

this time remove the buffering material placed in step (6).

- Make sure power supply wiring, transmission wiring, ground wiring and remote controller wiring are not caught inside the indoor unit.

■ When screwing in the indoor unit

- Remove the front grill. (Refer to Fig. 7)
- Secure the indoor unit to the installation panel (1) with the securing screws (6). (Refer to Fig. 11)

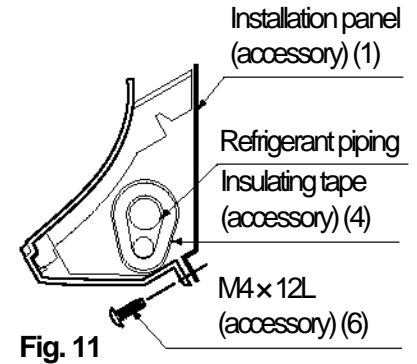

5. REFRIGERANT PIPING WORK

⟨For refrigerant piping of outdoor units, see the installation manual attached to the outdoor unit.⟩

⟨Execute heat insulation work completely on both sides of the gas piping and the liquid piping.

Otherwise, a water leakage can result sometimes.⟩

(When using a heat pump, the temperature of the gas piping can reach up to approximately 120°C, so use insulation which is sufficiently resistant.)

⟨Also, in cases where the temperature and humidity of the refrigerant piping sections might exceed 30°C or RH80 %, reinforce the refrigerant insulation. (20 mm or thicker) Condensation may form on the surface of the insulating material.⟩

⟨Before refrigerant piping work, check which type of refrigerant is used. Proper operation is not possible if the types of refrigerant are not the same.⟩

⚠ CAUTION

- Use a pipe cutter and flare suitable for the type of refrigerant.
- Apply ester oil or ether oil around the flare section before connecting.
- To prevent dust, moisture or other foreign matter from infiltrating the tube, either pinch the end or cover it with tape.
- Do not allow anything other than the designated refrigerant to get mixed into the refrigerant circuit, such as air, etc. If any refrigerant gas leaks while working on the unit, ventilate the room thoroughly right away.

- Do not mix air or other gas with the specified refrigerant in the refrigeration cycle.
- Ventilate the room if refrigerant gas leaks during the work.
- The outdoor unit is charged with refrigerant.
- Use copper alloy seamless pipes (ISO 1337)

- Be sure to use both a spanner and torque wrench together, as shown in the drawing, when connecting or disconnecting pipes to/from the unit. **(Refer to Fig. 12)**
- Refer to "Table 1" for the dimensions of flare nut spaces.
- When connecting the flare nut, coat the flare section (both inside and outside) with ester oil or ether oil, rotate three or four times first, then screw in. **(Refer to Fig. 13)**
- **Keep all the screw mounting resin parts (e.g., piping presser plates) away from oil.**
If oil adheres, the strength of the screw mounting resin parts may drop.

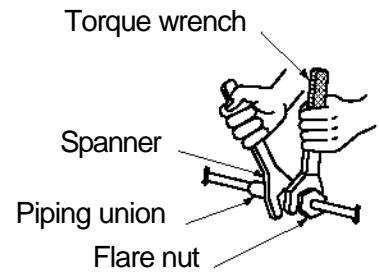

Fig. 12

Apply ester oil or ether oil only inside

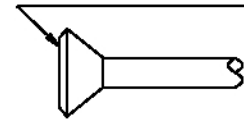

Fig. 13

CAUTION

- Over-tightening may cause the flare nuts to crack or the refrigerant to leak.

NOTE

- Use the flare nut included with the unit main body.

Table 1

Pipe size (Nm)	Tightening torque	Flare dimensions (mm)	Flare
φ 6.4 (1/4")	14.2 - 17.2	8.7 - 9.1	
φ 9.5 (3/8")	32.7 - 39.9	12.8 - 13.2	
φ 12.7 (1/2")	49.5 - 60.3	16.2 - 16.6	
φ 15.9 (5/8")	61.8 - 75.4	19.3 - 19.7	

- Refer to Table 1 to determine the proper tightening torque.

Not recommendable but in case of emergency

You must use a torque wrench but if you are obliged to install the unit without a torque wrench, you may follow the installation method mentioned below.

After the work is finished, make sure to check that there is no gas leak.

When you keep on tightening the flare nut with a spanner, there is a point where the tightening torque suddenly increases. From that position, further tighten the flare nut the angle shown below:

Table 2

Pipe size	Further tightening angle	Recommended arm length of tool
φ 6.4 (1/4")	60 - 90 degrees	Approx. 150mm
φ 9.5 (3/8")	60 - 90 degrees	Approx. 200mm
φ 12.7 (1/2")	30 - 60 degrees	Approx. 250mm
φ 15.9 (5/8")	30 - 60 degrees	Approx. 300mm

After the work is finished, make sure to check that there is no gas leak.

CAUTION

CAUTION TO BE TAKEN WHEN BRAZING REFRIGERANT PIPING

"Do not use flux when brazing refrigerant piping. Therefore, use the phosphor copper brazing filler metal (BCuP-2: JIS Z 3264/B-Cu93P-710/795: ISO 3677) which does not require flux."

(Flux has extremely harmful influence on refrigerant piping systems. For instance, if the chlorine based flux is used, it will cause pipe corrosion or, in particular, if the flux contains fluorine, it will damage the refrigerant oil.)

- Before brazing local refrigerant piping, nitrogen gas shall be blown through the piping to expel air from the piping.
If your brazing is done without nitrogen gas blowing, a large amount of oxide film develops inside the piping, and could cause system malfunction.
- When brazing the refrigerant piping, only begin brazing after having carried out nitrogen substitution or while inserting nitrogen into the refrigerant piping. Once this is done, connect the indoor unit with a flared or a flanged connection.
- Nitrogen should be set to 0.02 MPa with a pressure-reducing valve if brazing while inserting nitrogen into the piping. **(Refer to Fig.14)**

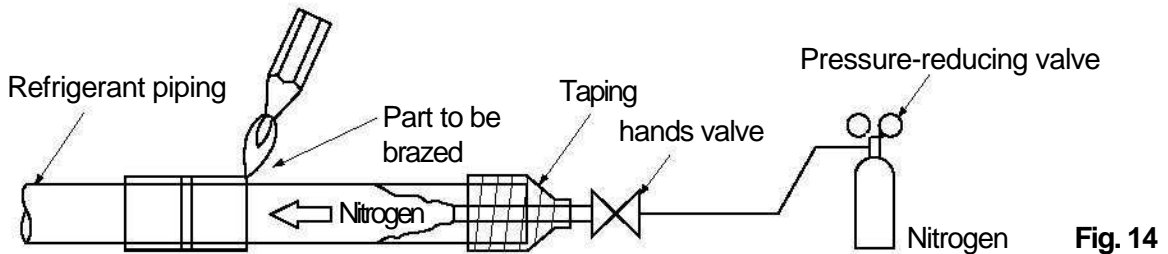

Fig. 14

CAUTION

Be sure to insulate any field piping all the way to the piping connection inside the unit. Any exposed piping may cause condensation or burns if touched.

- After checking for gas leaks, be sure to insulate the pipe connections using the supplementary piping insulation tubing and insulating tape (4). The insulating tape (4) should be wrapped from the L-shaped bend all the way to the end inside the unit. **(Refer to Fig. 15)**

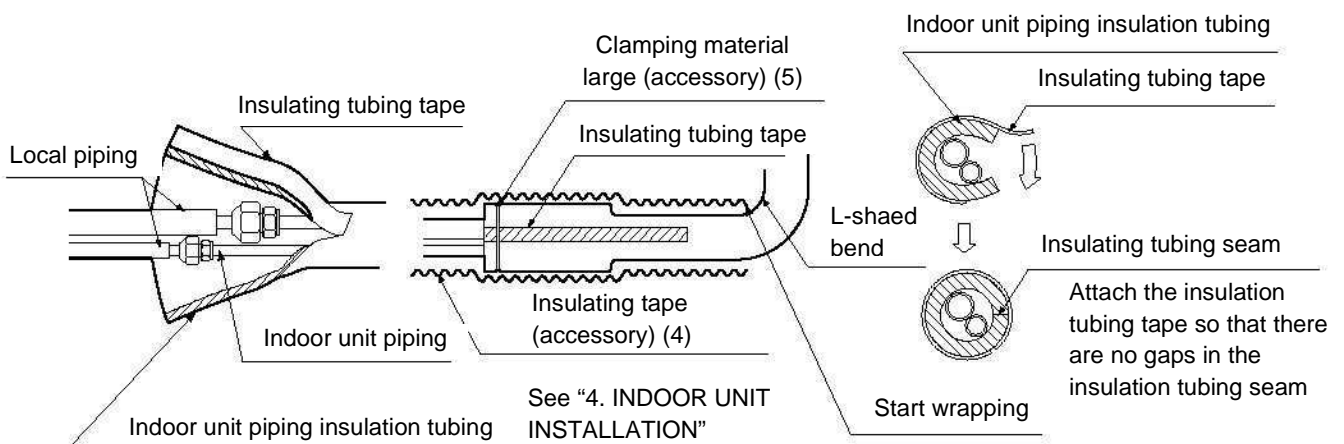

Fig. 15

CAUTION

Be sure to insulate any field piping all the way to the piping connection inside the unit. Any exposed piping may cause condensation or burns if touched.

6. DRAIN PIPING WORK

(1) Install the drain piping. (Refer to Fig. 16)

- The drain pipe should be short with a downward slope and should prevent air pockets from forming. • Watch out for the points in the Fig. 16 when performing drain work.

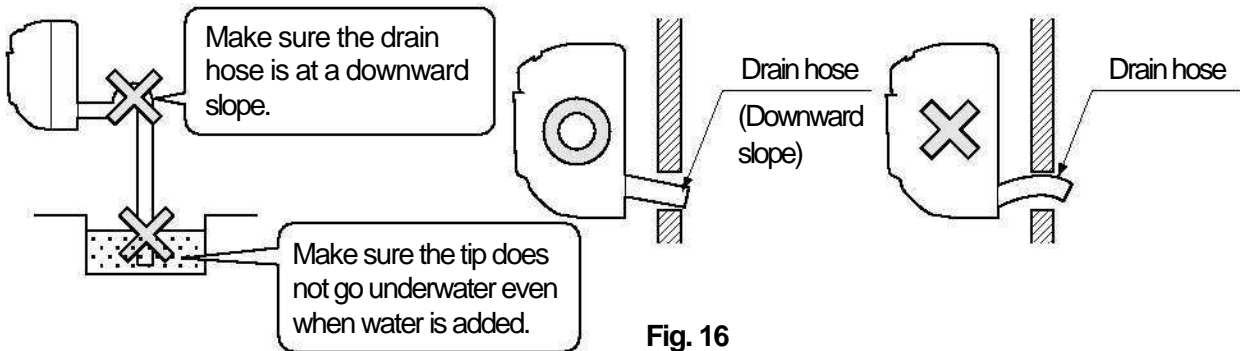

Fig. 16

- When extending the drain hose, use a commercially available drain extension hose, and be sure to insulate the extended section of the drain hose which is indoors. (Refer to Fig. 17)

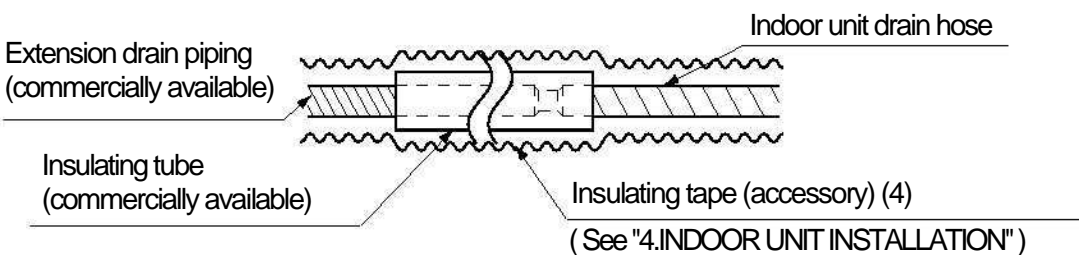

Fig. 17

- Make sure the diameter of the piping is the same as the piping (hard vinyl chloride, nominal diameter 13mm) or bigger.
- When directly connecting a hard vinyl chloride pipe joint (nominal diameter 13mm) to the drain hose connected to the indoor unit (i.e. for embedded piping, etc.), use a commercially available hard vinyl chloride pipe joint (nominal diameter 13mm). (Refer to Fig. 18)

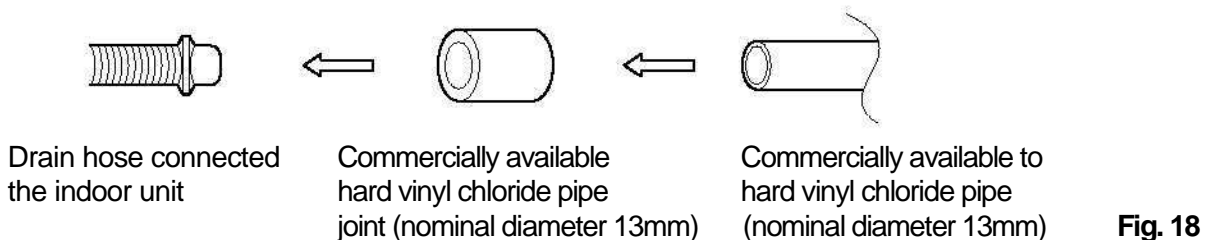

Fig. 18

(2) Make sure the drain works properly.

- After drain work is complete, perform a drain check by opening the front panel, **removing the air filter**, pouring water into the drain pan, and making sure water flows smoothly out of the drain hose. (Refer to Fig. 19)

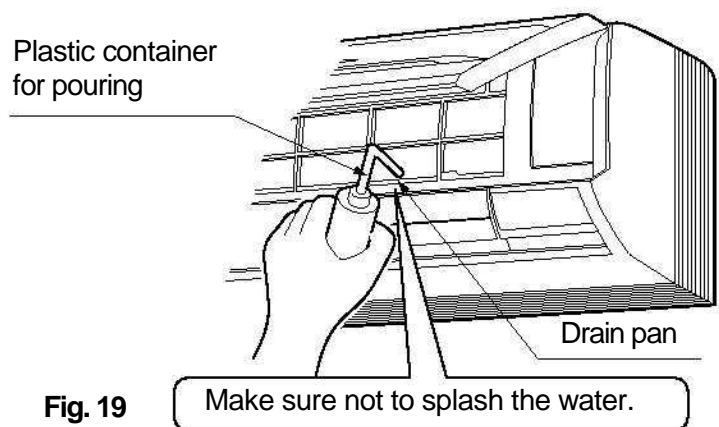

Fig. 19

⚠ CAUTION

- Drain piping connections

Do not connect the drain piping directly to sewage pipes that smell of ammonia. The ammonia in the sewage might enter the indoor unit through the drain pipes and corrode the heat exchanger.

- Keep in mind that it will become the cause of getting drain pipe blocked if water collects on drain pipe.

7. ELECTRIC WIRING WORK

7-1 GENERAL INSTRUCTIONS

- All field supplied parts and materials and electric works must conform to local codes.
- Use copper wire only.
- For electric wiring work, refer to also "WIRING DIAGRAM" attached to the unit body.
- For remote controller wiring details, refer to the installation manual attached to the remote controller.
- All wiring must be performed by an authorized electrician.
- This system consists of multiple indoor units. Mark each indoor unit as unit A, unit B..., and be sure the terminal board wiring to the outdoor unit and BS unit are properly matched. If wiring and piping between the outdoor unit and an indoor unit are mismatched, the system may cause a malfunction.
- A circuit breaker capable of shutting down power supply to the entire system must be installed.
- Refer to the installation manual attached to the outdoor unit for the size of power supply wiring connected to the outdoor unit, the capacity of the circuit breaker and switch, and wiring instructions.
- Be sure to ground the air conditioner.
- Do not connect the ground wire to gas pipes, water pipes, lightning rods, or telephone ground wires.
 - Gas pipes: might cause explosions or fire if gas leaks.
 - Water pipes: no grounding effect if hard vinyl piping is used.
 - Telephone ground wires or lightning rods: might cause abnormally high electric potential in the ground during lightning storms.

7-2 ELECTRICAL CHARACTERISTICS

Units				Power supply		Fan motor	
Model	Hz	Volts	Voltage range	MCA	MFA	kW	FLA
AXAP22PAD	50	220 - 240	Max. 264 Min. 198	0.3	16	0.040	0.2
AXAP28PAD				0.4	16	0.040	0.3
AXAP36PAD				0.4	16	0.040	0.3
AXAP45PAD				0.4	16	0.043	0.3
AXAP56PAD				0.5	16	0.043	0.4
AXAP71PAD				0.6	16	0.043	0.5

MCA: Min. Circuit Amps (A);

MFA: Max. Fuse Amps (A)

kW: Fan Motor Rated Output (kW);

FLA: Full Load Amps (A)

7-3 SPECIFICATIONS FOR FIELD SUPPLIED FUSES AND WIRE

Model	Power supply wiring			Remote controller wiring Transmission wiring	
	Field fuses 	Wire	Size	Wire	Size
AXAP22PAD	16A	H05VV - U3G	Wire size and length must comply with local codes.	Vinyl cord with sheath or cable (2 wire)	0.75 - 1.25 mm ²
AXAP28PAD					
AXAP36PAD					
AXAP45PAD					
AXAP56PAD					
AXAP71PAD					

Allowable length of transmission wirings and remote controller wiring are as follows.

(1) Outdoor unit - Indoor unit: Max. 1000m (Max. wiring length: 2000m)

(2) Indoor unit - Remote controller: Max. 500m

NOTE

1. Shows only in case of protected pipes. Use H07RN-F in case of no protection.
2. Vinyl cord with sheath or cable (Insulated thickness : 1mm or more)

⚠ CAUTION

- Arrange the wires and fix a lid firmly so that the lid does not float during wiring work.
- Do not clamp remote controller wiring and transmission wiring together with power supply wiring. Doing so may cause malfunction.
- Remote controller wiring and transmission wiring should be located at least 50 mm from power supply wiring. Not following this guideline may result in malfunction due to electrical noise.

8. HOW TO CONNECT WIRINGS AND WIRING EXAMPLE

8-1 HOW TO CONNECT WIRINGS

Methods of wiring power supply, units and connecting remote controller wiring

- Power supply wiring and ground wire
 Unscrew and remove the service lid.
 Connect the power supply wiring and ground wiring to the power supply terminal block (3P).
 When doing this, tie the power supply wiring and the ground wiring using the included clamp (small) (5) and then firmly secure using the included clamp (small) (5) according to the figure.
(Refer to Fig. 21)
- Transmission wiring and remote controller wiring
 Unscrew and remove the service lid.
 Connect the remote controller wiring and the transmission wiring to the terminal block (6P).
 When doing this, tie the remote controller wiring and the transmission wiring using the included clamp (small) (5) and then firmly secure using the included clamp (small) (5) according to the figure. **(Refer to Fig. 21)**
- Be sure to attach it to prevent the infiltration of water as well as any insects and other small creatures from the outside. Otherwise a short-circuit may occur inside the control box.

[PRECAUTIONS]

Observe the notes mentioned below when wiring to the power supply terminal block and terminal block for remote controller.

Tightening torque for the terminal blocks

- Use the correct screwdriver for tightening the terminal screws. If the blade of screwdriver is too small, the head of the screw might be damaged, and the screw will not be properly tightened. • If the terminal screws are tightened too hard, screws might be damaged. • Refer to the table below for the tightening torque of the terminal screws.

	Size	Tightening torque (N·m)
Terminal block for remote controller (6P)	M3.5	0.79 - 0.97
Power supply and Ground terminal block (3P)	M4	1.18 - 1.44

When none are available, follow the instructions below.

Do not connect wires of different gauge to the same grounding terminal.

Connect wires of the same gauge to both side.

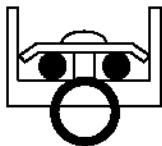

Do not connect wires of the same gauge to one side.

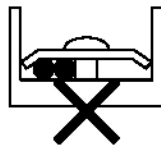

Do not connect wires of different gauges.

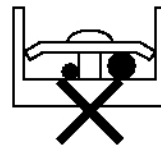

Looseness in the connection may deteriorate protection.

Precautions to be taken for power supply wiring

Use a round crimp-style terminal for connection to the power supply terminal block. In case it cannot be used due to unavoidable reasons, be sure to observe the following instructions.

Be sure to peel off the sheath of power supply wiring more than 40 mm. (Refer to Fig. 20)

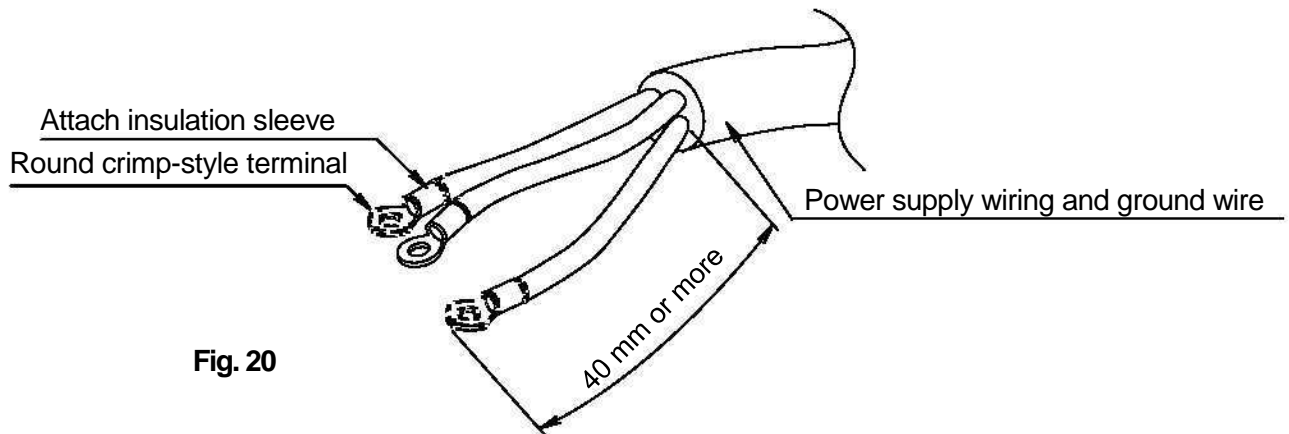

Fig. 20

- For remote controller wiring, refer to the "INSTALLATION MANUAL OF REMOTE CONTROLLER." attached to the remote controller.
- **Never connect power supply wiring to the terminal block for remote controller. A mistake of the sort could damage the entire system.**
- Use only specified wire and tightly connect wires to terminals. Be careful wires do not place external stress on terminals. Keep wiring in neat order and so as not to obstruct other equipment such as popping open the control box cover. Make sure the cover closes tight. Incomplete connections could result in overheating, and in worse case, electric shock or fire.

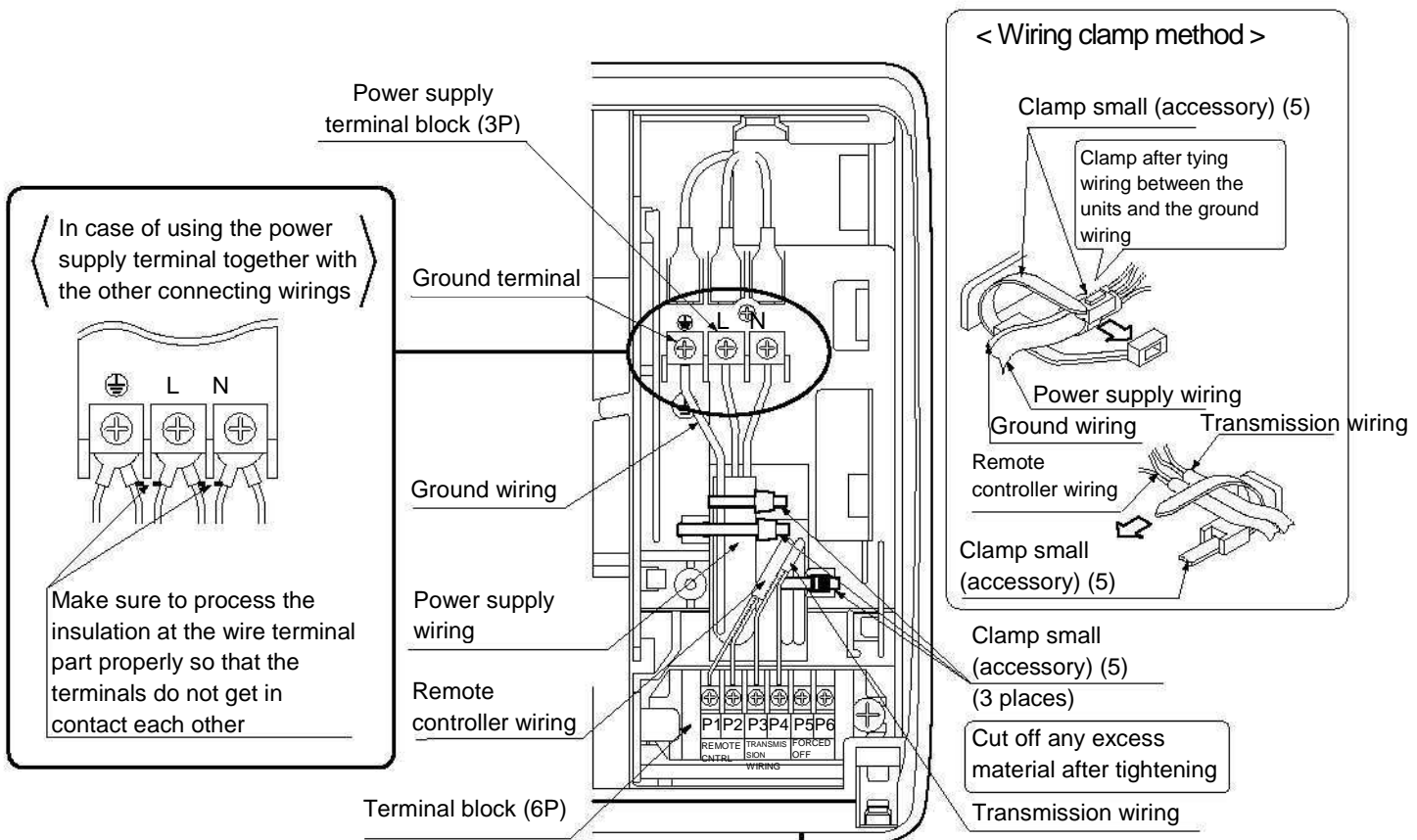

Fig. 21

⚠ CAUTION

- Be sure to attach the sealing material and putty (field supplied) to hole of wiring to prevent the infiltration of water as well as any insects and other small creatures from outside. Otherwise a short-circuit may occur inside the control box.
- When clamping the wirings, be sure no pressure is applied to the wire connections by using the included clamp to make appropriate clamps. Also, when wiring, make sure the lid on the control box fits snugly by arranging the wirings neatly and attaching the service lid firmly. When attaching the service lid, make sure no wirings get caught in the edges. Pass wiring through the wiring through holes to prevent damage to them.
- Make sure the remote controller wiring, and transmission wire the wiring between the units, and other electrical wiring do not pass through the same locations outside the machine, separating them by at least 50mm, otherwise electrical noise (external static) could cause mistaken operation or breakage.
- Use only specified wire and tightly connect wires to terminals. Be careful wires do not place external stress on terminals. Keep wiring in neat order and so as not to obstruct other equipment such as popping open the service cover. Make sure the cover closes tight. Incomplete connections could result in overheating, and in worse case, electric shock or fire.

8-2 WIRING EXAMPLE

- Fit the power supply wiring of each unit with a switch and fuse as shown in the drawing.

COMPLETE SYSTEM EXAMPLE (3 systems)

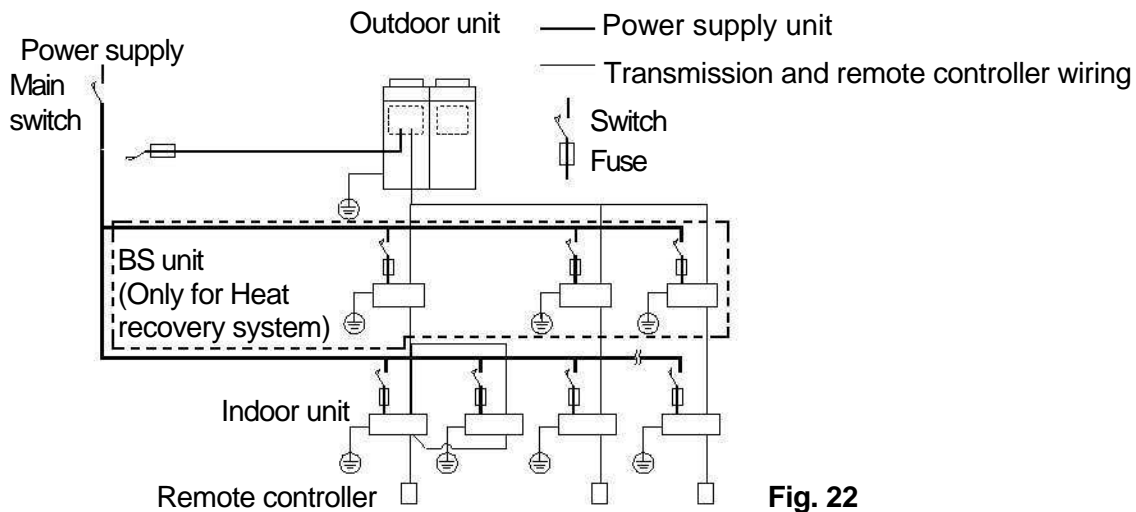

Fig. 22

1. When using 1 remote controller for 1 indoor unit. (Normal operation)

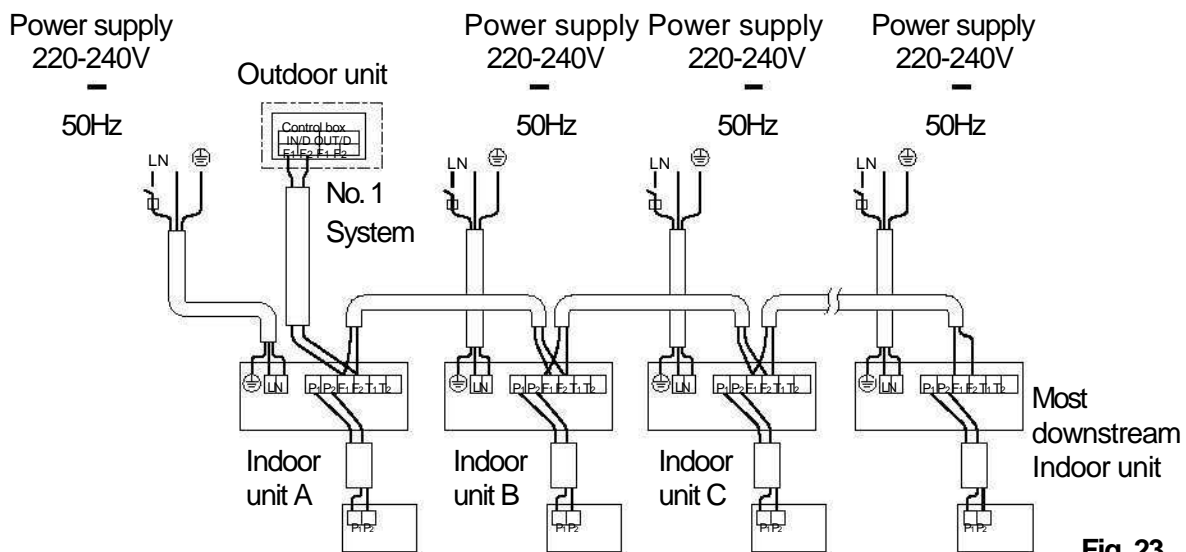

Fig. 23

2. For group control or use with 2 remote controllers

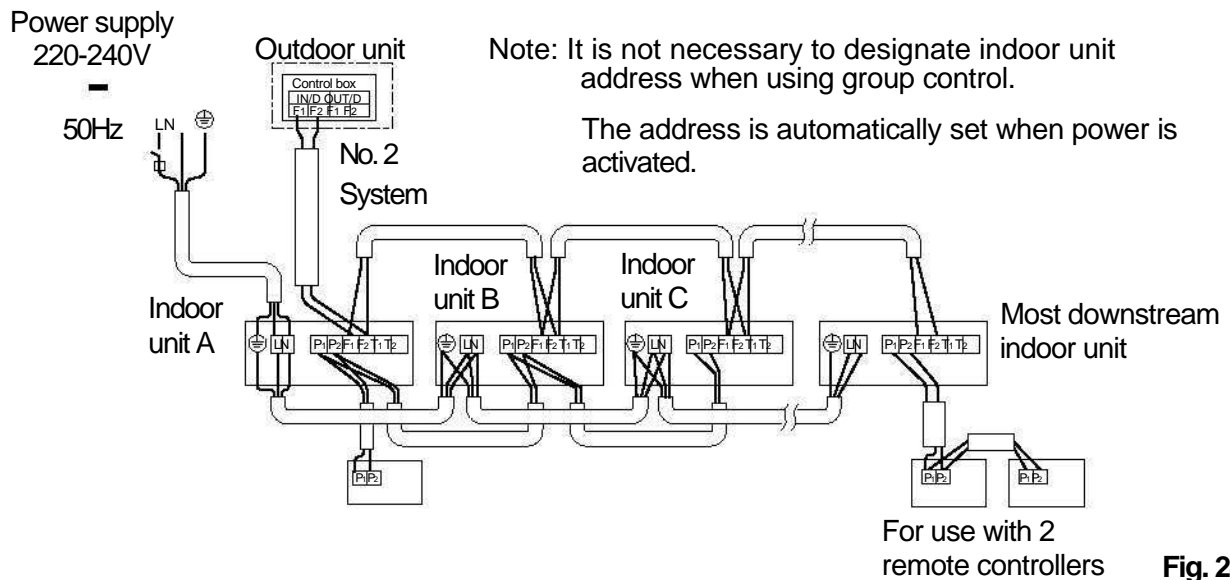

Fig. 24

3. When including BS unit

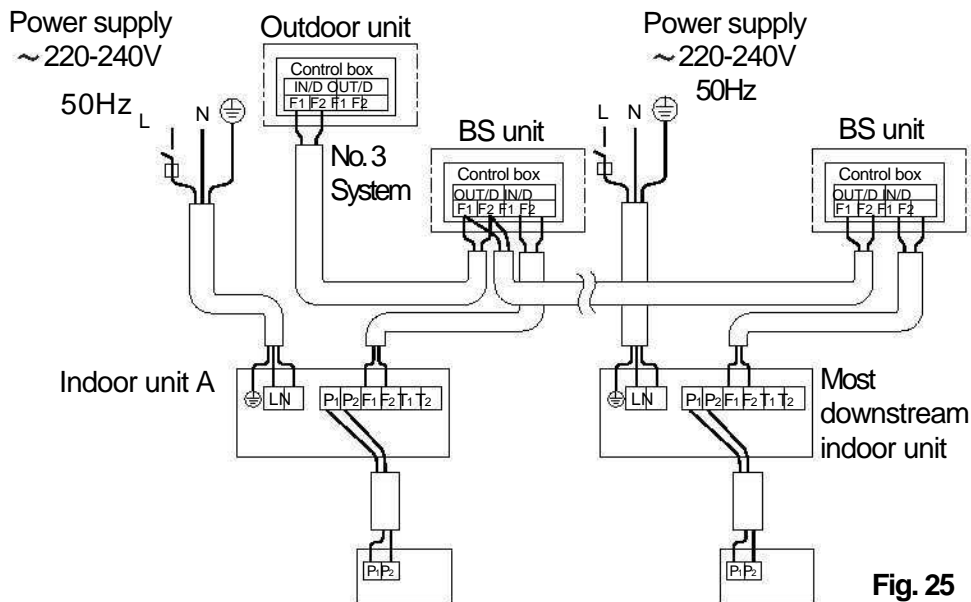

Fig. 25

[PRECAUTIONS]

1. All transmission wiring except for the remote controller wires is polarized and must match the terminal symbol.
2. A single switch can be used to supply power to units on the same system. However, branch switches and branch circuit breakers must be selected carefully.
3. Do not ground the equipment on gas pipes, water pipes or lightning rods, or cross ground with telephones. Improper grounding could result in electric shock.

8-3 CONTROL BY 2 REMOTE CONTROLLERS (CONTROLLING 1 INDOOR UNIT BY 2 REMOTE CONTROLLERS)

- When using 2 remote controllers, one must be set to "MAIN" and the other to "SUB".

MAIN/SUB CHANGEOVER

(1) Insert a  screwdriver into the recess between the upper and lower part of remote controller and, working from the 2 positions, pry off the upper part. The remote controller PC board is attached to the upper part of the remote controller. (Refer to Fig. 26)

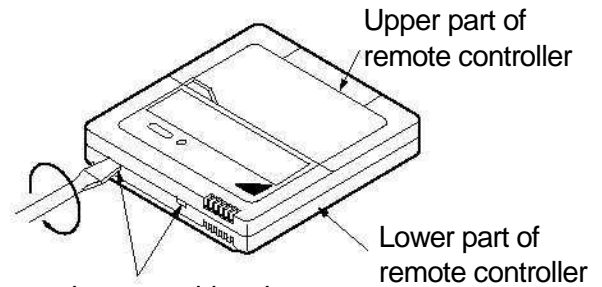

Insert the screwdriver here and gently work off the upper part of the remote controller. **Fig. 26**

(2) Turn the **main/sub changeover** switch on one of the two remote controller PC boards to "S". (Leave the switch of the other remote controller set to "M".) (Refer to Fig. 27)

Wiring Method (See "7.ELECTRIC WIRING WORK") (3)

Remove the service lid.

(4) Add remote control 2 (slave) to the terminal block (6P) for remote controller (P₁, P₂) in the control box. (There is no polarity.) (Refer to Fig. 24 and section 7-3 for the wiring size.)

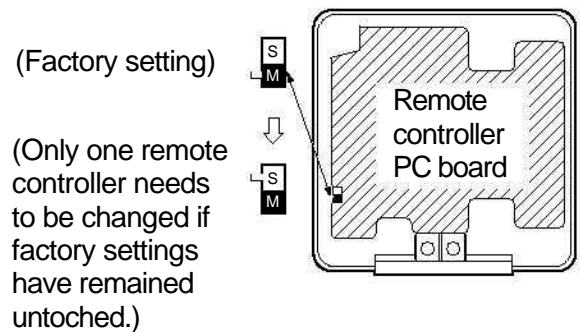

Fig. 27

8-4 COMPUTERISED CONTROL (FORCED OFF AND ON/OFF OPERATION)

(1) Wire specifications and how to perform wiring

- Connect the input from outside to terminals T1 and T2 of the terminal block (6P) for remote controller.

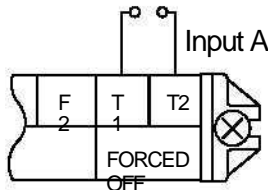

Fig. 28

Wire specification	Sheathed vinyl cord or cable (2 wire)
Gauge	0.75 - 1.25 mm ²
Lenght	Max. 100 m
External terminal	Contact that can ensure the minimum applicable load of 15V DC, 1 mA

(2) Actuation

- The following table explains FORCED OFF and ON/OFF OPERATIONS in response to Input A.

FORCED OFF	ON/OFF OPERATION
Input "ON" stops operation (impossible by remote controllers)	Input OFF → ON turns ON unit
Input OFF enables control by remote controller	Input ON → OFF turns OFF unit

(3) How to select FORCED OFF and ON/OFF OPERATION

- Turn the power on and then use the remote controller to select operation.

8-5 CENTRALIZED CONTROL

- For centralized control, it is necessary to designate the group No. For details, refer to the manual of each optional controllers for centralized control.

9. FIELD SETTINGS

⚠ CAUTION

When performing field setting or test operation without attaching the decoration panel, do not touch the drain pump. This may cause electric shock.

(1) Make sure the service lids are closed on the indoor and outdoor units.

(2) Field settings must be made from the remote controller and in accordance with installation conditions. •

Settings can be made by changing the "Mode No.", "FIRST CODE NO." and "SECOND CODE NO.".

- The "Field Settings" included with the remote control lists the order of the settings and method of operation.

*Setting is made in all units in a group. To set for individual indoor units or to check the setting, use the mode Nos. (with "2" in upper digit) in parentheses ().

9-1 SETTING AIR FILTER SIGN

- Remote controllers are equipped with liquid crystal display air filter signs to display the time to clean air filters.
- Change the SECOND CODE NO. according to Table 3 depending on the amount of dirt or dust in the room. (SECOND CODE NO. is factory set to "01" for air filter contamination-light)

Table 3

Setting	Spacing time of display air filter sign	Mode No.	FIRST CODE NO.	SECOND CODE NO.
Air filter contamination-light	Approx. 200 hrs	10 (20)	0	01
Air filter contamination-heavy	Approx. 100 hrs			02

9-2 SETTING AIR FLOWRATE INCREASE MODE

- It is possible to raise set airflow (HIGH and LOW) from the field. Change the SECOND CODE NO. as shown in Table 4 to suit your needs. (SECOND CODE NO. is factory set to "01" for Standard.)

Table 4

Setting	Mode No.	FIRST CODE NO.	SECOND CODE NO.
Standard	13 (23)	0	01
A little increase			02
Increase			03

<When using wireless remote controllers>

- When using wireless remote controllers, wireless remote controller address setting is necessary. Refer to the installation manual attached to the wireless remote controller for setting instructions.
 - Set the remote controller to the field set mode. For details, refer to the "HOW TO SET IN THE FIELD", in the remote controller manual.
 - When in the field set mode, select mode No. 12, then set the first code (switch) No. to "1". Then set second code (position) No. to "01" for FORCED OFF and "02" for ON/OFF OPERATION. (FORCED OFF at factory set) **(Refer to Fig. 29)**

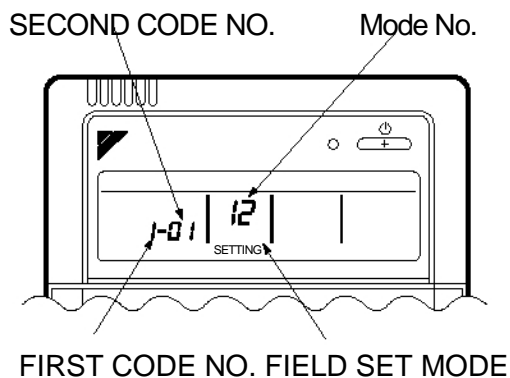

Fig. 29

10. TEST OPERATION

Make sure the service lids are closed on the indoor and outdoor units.

Refer to the installation manual of the outdoor unit.

- The operation lamp of the remote controller will flash when a malfunction occurs. Check the malfunction code on the liquid crystal display to identify the point of trouble. An explanation of malfunction codes and the corresponding trouble is provided in "CAUTION FOR SERVICING" of the indoor unit.

If any of the items in Table 5 are displayed, there may be a problem with the wiring or power, so check the wiring again.

Table 5

Remote controller display	Content
"Concentrated Management" is lit up	<ul style="list-style-type: none"> • There is a short circuit at the FORCED OFF terminals (T1, T2). •
"U4" is lit up "UH" is lit up	<p>The power on the outdoor unit is off.</p> <ul style="list-style-type: none"> • The outdoor unit has not been wired for power supply. • Incorrect wiring for the transmission wiring and/or FORCED OFF wiring. • The branch wiring is cut.
No display	<ul style="list-style-type: none"> • The power on the indoor unit is off. • The indoor unit has not been wired for power supply. • Incorrect wiring for the remote controller wiring, the transmission wiring, and/or the FORCED OFF wiring. • <p>The remote controller wiring is cut.</p>

- In order to protect the indoor unit, instruct the customer not to operate the air conditioner until the interior work is completed if the interior work has not been finished at the end of the test run.
(If the air conditioner is operated, substances discharged from the paint, adhesive, etc. can contaminate the indoor unit, and they may cause splashing or leakage of water.)

NOTE

- After the test run is finished, check the items listed in "**b. Items to be checked at time of delivery**".

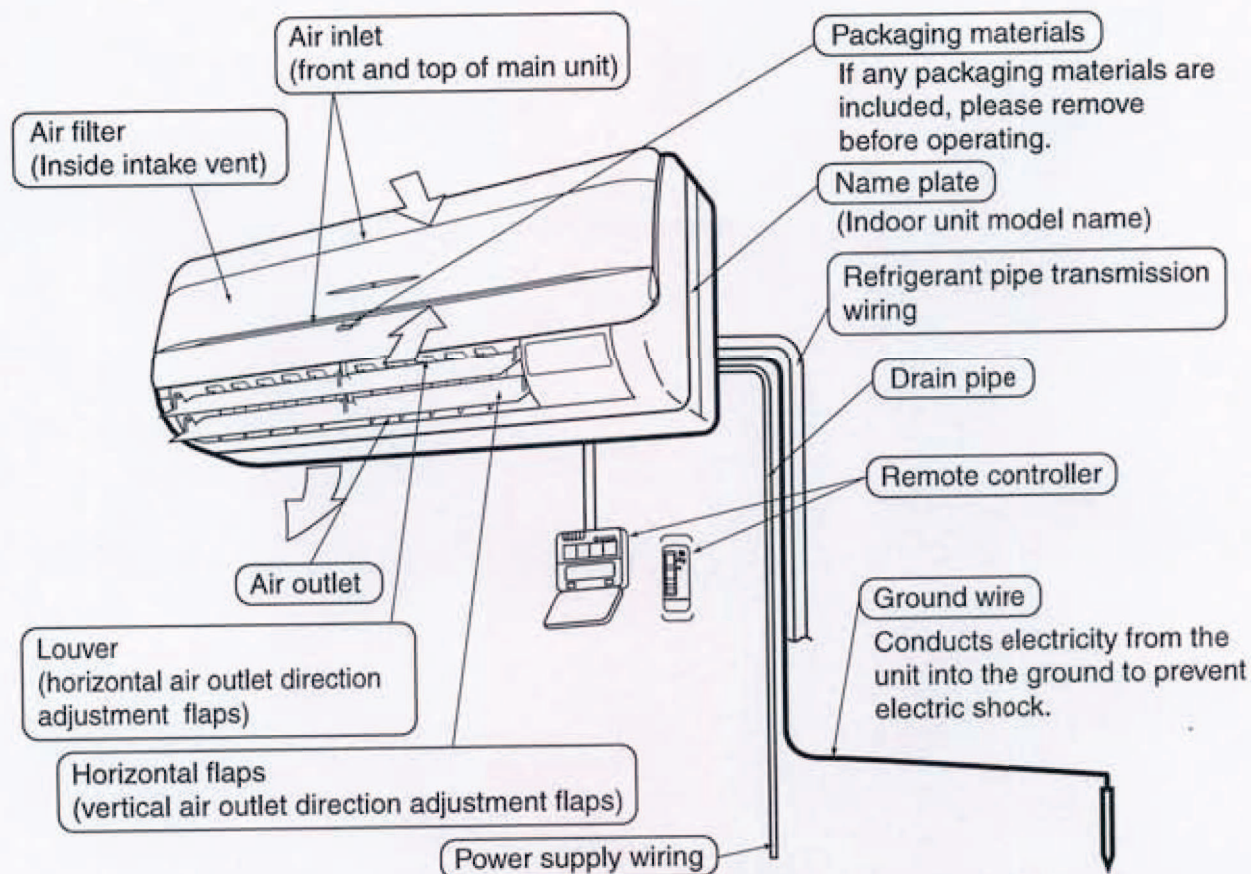

Thank you for purchasing this Daikin air conditioner. Carefully read this operation manual before using the air conditioner. It will tell you how to use the unit properly and help you if any trouble occurs. This manual explains about the indoor unit only. Use it along with the operation manual for the outdoor unit. After reading the manual, file it away for future reference.

The English text is the original instruction. Other languages are translations of the original instructions.

Important information regarding the refrigerant used

This product contains fluorinated greenhouse gases covered by the Kyoto Protocol.

Refrigerant type	R410A
GWP ⁽¹⁾ value	1975

⁽¹⁾ GWP = global warming potential

Periodical inspections for refrigerant leaks may be required depending on European or local legislation. Please contact your local dealer for more information.

SAFETY PRECAUTIONS

To gain full advantage of the air conditioner's functions and to avoid malfunction due to mishandling, please read this operation manual carefully before use.

This air conditioner is classified under "appliances not accessible to the general public".

- **The precautions described herein are classified as WARNING and CAUTION. They both contain important information regarding safety. Be sure to observe all precautions without fail.**

⚠ **WARNING** Failure to follow these instructions properly may result in personal injury or loss of life.

⚠ **CAUTION** Failure to observe these instructions properly may result in property damage or personal injury, which may be serious depending on the circumstances.

- **After reading, keep this manual in a convenient place so that you can refer to it whenever necessary. If the equipment is transferred to a new user, be sure also to hand over the manual.**

⚠ WARNING

- **Consult your local dealer about installation work.**
Doing the work yourself may result in water leakage, electric shocks or fire hazards.
- **Consult your local dealer regarding modification, repair and maintenance of the air conditioner.**
Improper workmanship may result in water leakage, electric shocks or fire hazards.
- **Beware of fire in case of refrigerant leakage.**
If the air conditioner is not operating correctly, i.e. not generating cool or warm air, refrigerant leakage could be the cause.
Consult your dealer for assistance.
The refrigerant used for the air conditioner is safe and normally does not leak. However, if the refrigerant leaks and gets in contact with a naked burner, heater or cooker, it may generate hazardous compounds. Turn off the air conditioner and call the dealer. Make sure to turn on the air conditioner after the qualified service person confirms that the leakage is repaired.
- **Consult your local dealer regarding relocation and reinstallation of the air conditioner.**
Improper installation work may result in leakage, electric shocks or fire hazards.

⚠ CAUTION

- **Do not allow a child to mount on the outdoor unit or avoid placing any object on it.**
Falling or tumbling may result in injury.
 - **The appliance is not intended for use by unattended young children or persons who are incompetent to operate air conditioners.**
It may result in injury or electric shock.
 - **Children should be watched so that they do not play with the unit or its remote controller.**
Accidental operation by a child may result in injury or electric shock.
 - **Do not place objects in direct proximity of the outdoor unit and do not let leaves and other debris accumulate around the unit.**
Leaves are a hotbed for small animals which can enter the unit. Once in the unit, such animals can cause malfunctions, smoke or fire when making contact with electrical parts.
 - **Do not let children play on or around the outdoor unit.**
If they touch the unit carelessly, injury may be caused.
-

HOW TO ADJUST THE HORIZONTAL FAN DIRECTION ANGLE

Hold the tabs on edge louvers (horizontal air outlet direction adjustment flaps) down slightly and adjust left and right to match the room conditions or your preference.

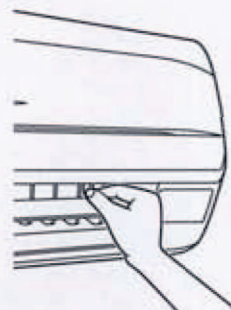

Stop the horizontal flaps at a position where you can hold the tabs and adjust it left and right.

MAINTENANCE (FOR SERVICE PERSONNEL)

⚠ WARNING

- **Only a qualified person is allowed to perform maintenance without daily maintenance.**
 - **Before touching any of connection wirings, be sure to turn off all power supply switches.**
 - **Contact professional personnel about attachment of accessories and be sure to use only accessories specified by the manufacturer.**
If a defect results from your own workmanship, it may result in water leaks, electric shock or fire.
 - **Do not use flammable materials (e.g., hair-spray or insecticide) near the product.**
Do not clean the product with organic solvents such as paint thinner.
The use of organic solvents may cause crack damage to the product, electric shocks, or fire.
 - **Consult your dealer regarding cleaning the inside of the air conditioner.**
Improper cleaning may cause breakage of plastic parts, water leakage and other damage as well as electric shocks.
-

— **⚠ CAUTION** —

- **Before cleaning, be sure to stop unit operation, turn the power circuit breaker off or remove the power cord.**

Otherwise, an electric shock and injury may result.

- **Do not wash the air conditioner with water, as this may result in electric shocks or fire.**
- **Watch your steps at the time of air filter cleaning or inspection.**

High-place work is required, to which utmost attention must be paid.

If the scaffold is unstable, you may fall or topple down, thus causing injury.

NOTE 

- Do not remove the air filter except when cleaning. This may cause breakage.

HOW TO CLEAN THE AIR FILTER

Clean the air filter when the display shows “” (TIME TO CLEAN AIR FILTER).

- It will display that it will operate for a set amount of time.
- Increase the frequency of cleaning if the unit is installed in a room where the air is extremely contaminated.
- If the dirt becomes impossible to clean, change the air filter (Air filter for exchange is optional)

1. Open the front panel.

Place your fingers on the panel protrusions on the left and right sides of the main unit and open until the panel stops.

(Follow the same procedure for closing.)

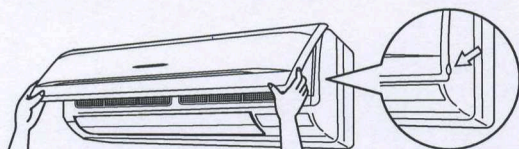

2. Pullout the air filter.

Push up the tab in the center of the air filter slightly then pull out in a downward direction.

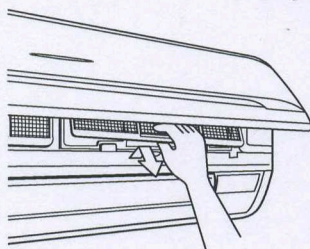

3. Clean the air filter.

Use vacuum cleaner **A)** or wash the air filter with water **B)**.

A) Using a vacuum cleaner



B) Washing with water

When the air filter is very dirty, use soft brush and neutral detergent



Remove water and dry in the shade.

NOTES 

- Do not wash the air filter with hot water of more than 50°C, as doing so may result in discoloration and/or deformation.
- Do not expose it to fire, as doing so may result in burning.

4. Attach the air filter.

Once cleaning is done be sure to replace the air filter as it was.

5. Shut the front panel.

Refer to item No.1.

6. Press the FILTER SIGN RESET button on the remote controller.

The “TIME TO CLEAN AIR FILTER” display vanishes.

HOW TO CLEAN THE AIR OUTLET AND EXTERIOR

- Clean with soft cloth.
- When it is difficult to remove stains, use water or neutral detergent.

NOTES 

- Do not use gasoline, benzene, thinner, polishing powder, liquid insecticide. It may cause discoloring or warping.
- Do not use water or air of 50°C or higher for cleaning air filters.
- When the flap is extremely contaminated, remove it as below and clean or exchange it. (Flap for exchange is optional.)

HOW TO CLEAN THE FRONT PANEL

You can remove the front panel to clean it.

NOTES

- Hold the front panel firmly so that it does not fall.
- Do not use gasoline, benzene, thinner, polishing powder, liquid insecticide. It may cause discoloring or warping.
- Do not let the indoor unit get wet. It may cause an electric shock or a fire.
- Do not scrub firmly when washing the blade with water.
The surface sealing may peel off.
- Do not use water or air of 50°C or higher for cleaning air filters and outside panels.
- Make sure the front panel is solidly in place.

1. Open the front panel.

Place your fingers on the panel protrusions on the left and right sides of the main unit and open until the panel stops.
(Follow the same procedure for closing.)

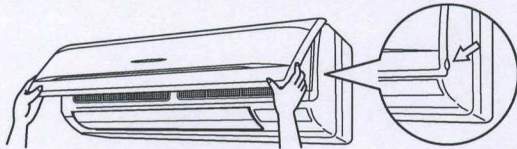

2. Remove the front panel.

Push the axes on either side of the front panel towards the center of the main unit and remove.
(You can also remove it by sliding the front panel either to the left or right and pulling it forward.)

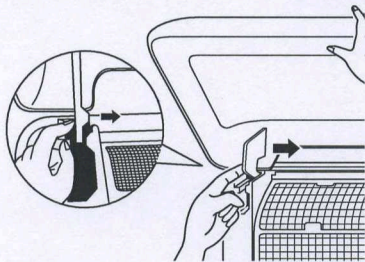

3. Clean the front panel.

- Wipe gently with a soft wet cloth.
- Only use neutral cleaning agents.
- After washing off, wipe off any excess water and dry in a shaded location.
- **When very grimy**
Directly apply the type of detergent used for cleaning ventilation fans or ovens, wait 10 minutes, and then rinse with water.

NOTE

- Do not wash the air conditioner with hot water of more than 50°C. Doing so may result in discoloration or deformation.

4. Attach the front panel.

Set the keys of the front panel into the slots and push them in all the way.
Close the front panel slowly in this state.

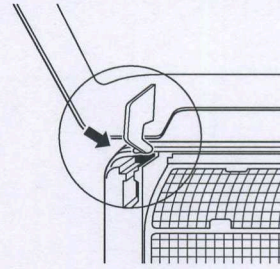

AISIN
Geared up for the future



0051
0497
05/004/8

Made in Japan

Distributore Unico Europeo - *European sole distributor*

TECNOCASA
CLIMATIZZAZIONE

Via Manzoni, 17 - 60025 Loreto (AN) - Italy
Tel. +39 071 977805 - Fax +39 071 976481
www.tecno-casa.com - www.aisin.it
info@tecno-casa.com