

(Additional refilling amount of the refrigerant oil when repairing the refrigerant system)

●Specified refrigerant oil	NL10
●Amount of refrigerant oil	4L *1

*1 : It is no necessary to refilling the refrigerant oil when install the outdoor unit.

Additional refilling amount of the refrigerant oil

Replacement parts / Operation *2	Additional refilling amount
●Accumulator	1,000cm ³
●Oil separator	2,000cm ³ *3
●Compressor (intake side)	50cm ³ / pcs
●Compressor (discharge side)	150cm ³ / pcs
●Other than the above	Measured amount *3
●Recovering refrigerant	All of the above + 400cm ³ *4

*2 : When replacing more than one part in the refrigerant system, add up the additional refilling amount of refrigerant oil for each parts and refill the specified.

*3 : When replacing the oil separator, discharge the refrigerant oil in the oil separator by nitrogen pressure. Measure the amount of refrigeration oil discharged and refill the measured amount.

*4 : Ex) When performing the following maintenance, add up the additional refilling amount of refrigerant oil. Refer to the manual and refill the TOTAL amount of refrigerant oil.

Operation	Additional refilling amount of the refrigerant oil
●Recovering refrigerant	400cm ³
●Replace an accumulator	1000cm ³
●Measure the amount of refrigeration oil recovered from the oil separator	1500cm ³
TOTAL	2900cm ³

(When there is a possibility of backflow of the refrigerant oil after refilling them)

If the following phenomena occur during vacuuming suction after refilling the refrigerant oil, the refrigerant oil is flowing out of the refrigerant circuit. Please close the gauge manifold.

- ①The refrigerant oil return to sight glass of gauge manifold. (Backfolw)
- ②White smoke comes from the vacuum pump.

(Necessary tools)

- Hoses with one-sided pin joint for refilling the refrigerant oil
- Gauge manifold
- Vacuum pump
- Vacuum gauge
- Control valve
- Heat gun

(Refilling refrigerant oil when the outside temperature is low)

It may take longer to refill the refrigerant oil when the outside temperature is low and the refrigerant oil will be high viscosity. We will recommend to use heat gun for warm the refrigerant oil can before use. It will help to reduce the refilling time.

(Refrigerant recovery / Vacuuming operation (code No.06)" in the command mode)

When Recovery refrigerant / Vacuum Suction, make sure to set "Refrigerant recovery / Vacuuming operation (code No.06)" in the command mode before the operation.

When set "Refrigerant recovery / Vacuuming operation (code No.06)" in the command mode, Remote control operation will be prohibited / Operation of outdoor units will be prohibited / Expansion valve and solenoid valve of indoor and outdoor units fully open.

If not set, refrigerant recovery and vacuuming cannot be performed correctly.

【Refrigerant oil refilling method】

●Refrigerant recovery of INDOOR UNIT only	
●Outdoor unit type	ALL types

- After replacing parts, turn on the breaker of the outdoor unit.
- Set "Refrigerant recovery / Vaccuming operation (code No.06)" in the command mode.
*When set "Refrigerant recovery / Vaccuming operation (code No.06)" in the command mode, Remote control operation will be prohibited / Operation of outdoor units will be prohibited / Expansion valve and solenoid valve of indoor and outdoor units fully open.
- Connect the gauge manifold to service port of stop valve for liquid(■) and service port of stop valve for vapor(■).
Connect the gauge manifold to Vacuum pump and attach the Vacuum gauge.
*It is recommended to attach a control valve on the service port.
- Turn on the vacuum pump "ON" and perform vacuum suction.
It will be needed to perform vacuum suction a few minutes in order to suck up the refrigerant oil.
- Remove the hose from service port of stop valve for liquid(■) .
Remove the control valve from service port of stop valve for liquid.
- Open the lid of refrigerant oil can and pour the specified amount of refrigerant oil into the beaker.
Insert the hose for refilling the refrigerant oil into the beaker. (the side without a pin joint)
- Connect the hose (the side with a pin joint) for refilling the refrigerant oil to service port of stop valve for liquid(■).
*Before this step, push the pin joint of the service port and confirm the refrigerant circuit pressure is low.
*Do not to attach a control valve. The refrigerant oil will not flow smoothly due to the control valve.
- Insert the hose fully into the refrigerant oil in order not to let in the air.
Refill the specified amount of refrigerant oil.
- After refilling the refrigerant oil, cover the no-pin joint side of the hose with your finger in order not to let in the air in the hose for for refilling the refrigerant oil.
Remove the hose for for refilling the refrigerant oil.
- After more than 10 minutes, connect the charging hose to service port of stop valve for liquid(■) and open the valve.
*It must be took a Interval over 10 minutes after refilling the refrigerant oil, because it may happen backflow the refrigerant oil.
- Measure pressure with a vacuum gauge.
Operating the vacuum pump for over 2hours after the pressure drops to -101kPa.

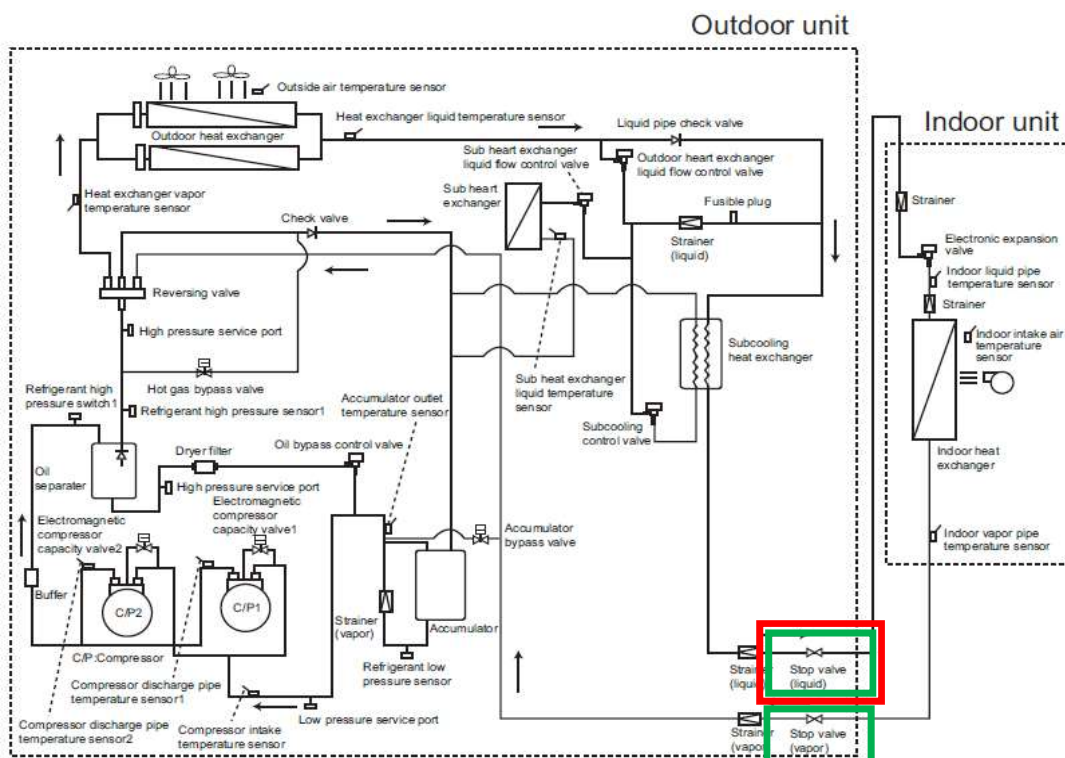

【Refrigerant oil refilling method】

●Refrigerant recovery of OUTDOOR UNIT only

●Outdoor unit type

F model

1. After replacing parts, turn on the breaker of the outdoor unit.
2. Set "Refrigerant recovery / Vaccuming operation (code No.06)" in the command mode.
*When set "Refrigerant recovery / Vaccuming operation (code No.06)" in the command mode, Remote control operation will be prohibited / Operation of outdoor units will be prohibited / Expansion valve and solenoid valve of indoor and outdoor units fully open.
3. Connect the gauge manifold to service port of high-pressure(■) and to service port of low-pressure(■).
Connect the gauge manifold to vacuum pump and attach the vacuum gauge.
*It is recommended to attach a control valve on the service port of high-pressure and low-pressure.
4. Turn on the vacuum pump "ON" and perform vacuum suction.
It will be needed to perform vacuum suction a few minutes in order to suck up the refrigerant oil.
5. Open the lid of refrigerant oil can and pour the specified amount of refrigerant oil into the beaker. Insert the hose for refilling the refrigerant oil into the beaker. (the side without a pin joint)
6. Connect the hose (the side with a pin joint) for refilling the refrigerant oil to service port of high pressure(■).
*Before this step, push the pin joint of the service port and confirm the refrigerant circuit pressure is low.
*Do not to attach a control valve. The refrigerant oil will not flow smoothly due to the control valve.
7. Insert the hose fully into the refrigerant oil in order not to let in the air. Refill the specified amount of refrigerant oil.
8. After refilling the refrigerant oil, cover the no-pin joint side of the hose with your finger in order not to let in the air in the hose for for refilling the refrigerant oil. Remove the hose for for refilling the refrigerant oil.
*Put the caps on the port from which the hose removed.
9. Measure pressure with a vacuum gauge.
Operating the vacuum pump for over 2hours after the pressure drops to -101kPa .

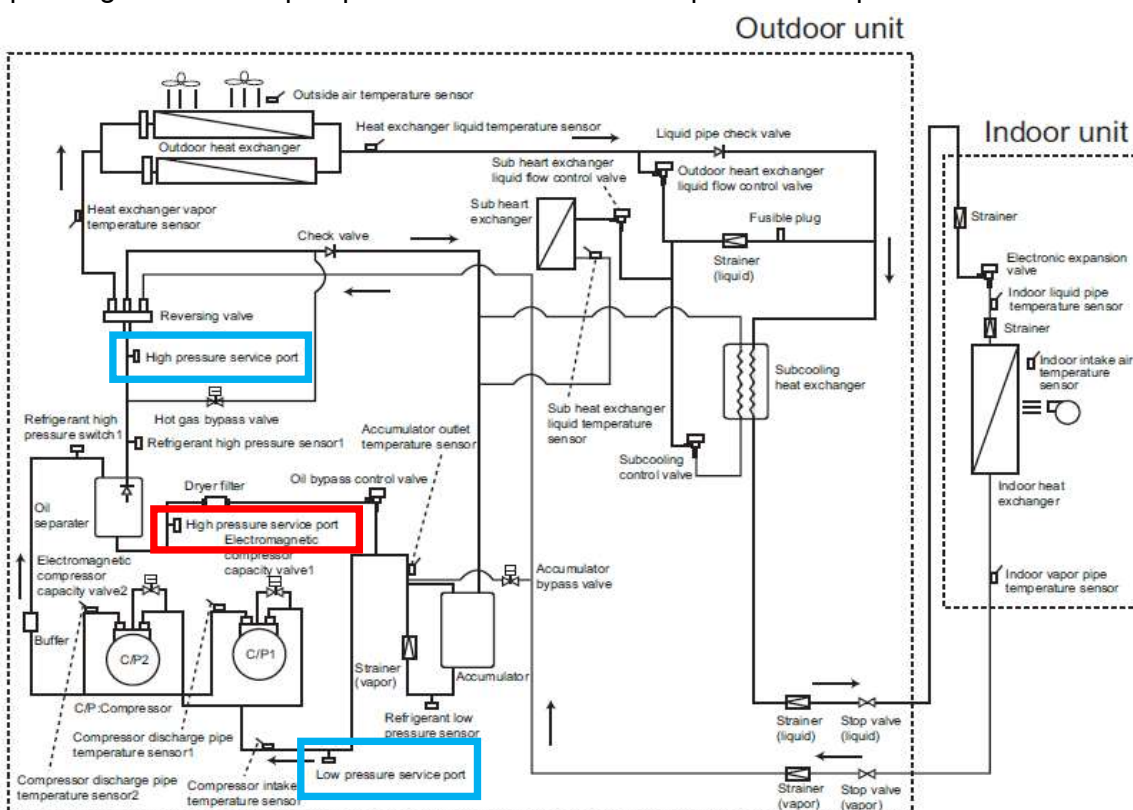

【Refrigerant oil refilling method】

●Refrigerant recovery of overall the system (OUTDOOR UNIT· INDOOR UNIT)

●Outdoor unit type

F model

1. After replacing parts, turn on the breaker of the outdoor unit.
2. Set "Refrigerant recovery / Vaccuming operation (code No.06)" in the command mode.
*When set "Refrigerant recovery / Vaccuming operation (code No.06)" in the command mode, Remote control operation will be prohibited / Operation of outdoor units will be prohibited / Expansion valve and solenoid valve of indoor and outdoor units fully open.
3. Connect the gauge manifold to service port of stop valve for liquid(■) and service port of stop valve for vapor(■).
Connect the gauge manifold to vacuum pump and attach the vacuum gauge.
*It is recommended to attach a control valve on the service port.
4. Turn on the vacuum pump "ON" and perform vacuum suction.
It will be needed to perform vacuum suction a few minutes in order to suck up the refrigerant oil.
5. Open the lid of refrigerant oil can and pour the specified amount of refrigerant oil into the beaker. Insert the hose for refilling the refrigerant oil into the beaker. (the side without a pin joint)
6. Connect the hose (the side with a pin joint) for refilling the refrigerant oil to service port of high pressure(■).
*Before this step, push the pin joint of the service port and confirm the refrigerant circuit pressure is low.
*Do not to attach a control valve. The refrigerant oil will not flow smoothly due to the control valve.
7. Insert the hose fully into the refrigerant oil in order not to let in the air.
Refill the specified amount of refrigerant oil.
8. After refilling the refrigerant oil, cover the no-pin joint side of the hose with your finger in order not to let in the air in the hose for for refilling the refrigerant oil.
Remove the hose for for refilling the refrigerant oil.
*Put the caps on the port from which the hose removed.
9. Measure pressure with a vacuum gauge.
Operating the vacuum pump for over 2hours after the pressure drops to -101kPa .

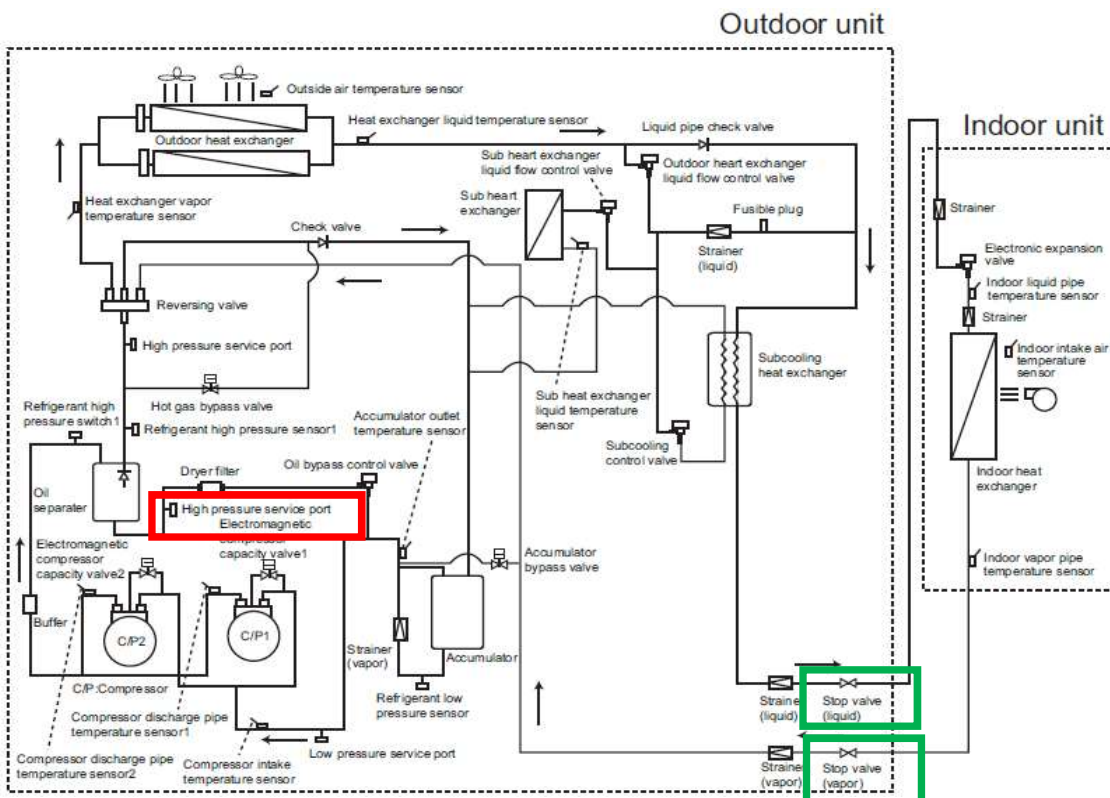

【Refrigerant oil refilling method】

●Refrigerant recovery of OUTDOOR UNIT only

●Outdoor unit type	E model (224 / 280 / 355)
--------------------	-----------------------------

1. After replacing parts, turn on the breaker of the outdoor unit.
2. Set "Refrigerant recovery / Vaccuming operation (code No.06)" in the command mode.
*When set "Refrigerant recovery / Vaccuming operation (code No.06)" in the command mode, Remote control operation will be prohibited / Operation of outdoor units will be prohibited / Expansion valve and solenoid valve of indoor and outdoor units fully open.
3. Connect the gauge manifold to service port of high-pressure(■) and to service port of low-pressure(■)
Connect the gauge manifold to vacuum pump and attach the vacuum gauge.
*It is recommended to attach a control valve on the service port of high-pressure and low-pressure.
4. Turn on the vacuum pump "ON" and perform vacuum suction.
It will be needed to perform vacuum suction a few minutes in order to suck up the refrigerant oil.
5. Remove the hose from high-pressure service port (■) .
Remove the control valve.
6. Open the lid of refrigerant oil can and pour the specified amount of refrigerant oil into the beaker.
Insert the hose for refilling the refrigerant oil into the beaker. (the side without a pin joint)
7. Connect the hose (the side with a pin joint) for refilling the refrigerant oil to service port of high-pressure(■).
*Before this step, push the pin joint of the service port and confirm the refrigerant circuit pressure is low.
*Do not to attach a control valve. The refrigerant oil will not flow smoothly due to the control valve.
8. Insert the hose fully into the refrigerant oil in order not to let in the air.
Refill the specified amount of refrigerant oil.
9. After refilling the refrigerant oil, cover the no-pin joint side of the hose with your finger in order not to let in the air in the hose for for refilling the refrigerant oil.
Remove the hose for for refilling the refrigerant oil.
10. After more than 10 minutes, connect the charging hose to to service port of high-pressure(■) and open the valve.
*It must be took a Interval over 10 minutes after refilling the refrigerant oil, because it may happen backflow the refrigerant oil.
11. Measure pressure with a vacuum gauge.
Operating the vacuum pump for over 2hours after the pressure drops to -101kPa .

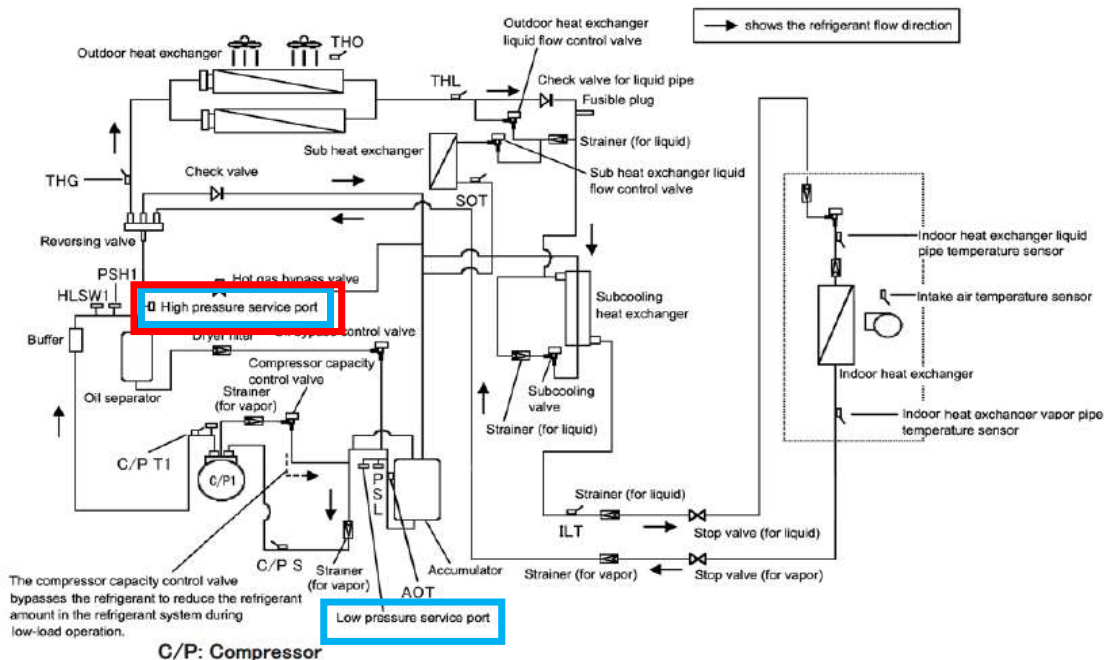

【Refrigerant oil refilling method】

●Refrigerant recovery of overall the system (OUTDOOR UNIT· INDOOR UNIT)

●Outdoor unit type

E model (224 / 280 / 355)

1. After replacing parts, turn on the breaker of the outdoor unit.
2. Set "Refrigerant recovery / Vaccuming operation (code No.06)" in the command mode.
*When set "Refrigerant recovery / Vaccuming operation (code No.06)" in the command mode, Remote control operation will be prohibited / Operation of outdoor units will be prohibited / Expansion valve and solenoid valve of indoor and outdoor units fully open.
3. Connect the gauge manifold to service port of stop valve for liquid(■) and service port of stop valve for vapor(■).
Connect the gauge manifold to vacuum pump and attach the vacuum gauge.
*It is recommended to attach a control valve on the service port.
4. Turn on the vacuum pump "ON" and perform vacuum suction.
It will be needed to perform vacuum suction a few minutes in order to suck up the refrigerant oil.
5. Open the lid of refrigerant oil can and pour the specified amount of refrigerant oil into the beaker. Insert the hose for refilling the refrigerant oil into the beaker. (the side without a pin joint)
6. Connect the hose (the side with a pin joint) for refilling the refrigerant oil to service port of high-pressure(■).
*Before this step, push the pin joint of the service port and confirm the refrigerant circuit pressure is low.
*Do not to attach a control valve. The refrigerant oil will not flow smoothly due to the control valve.
7. Insert the hose fully into the refrigerant oil in order not to let in the air. Refill the specified amount of refrigerant oil.
8. After refilling the refrigerant oil, cover the no-pin joint side of the hose with your finger in order not to let in the air in the hose for for refilling the refrigerant oil.
Remove the hose for for refilling the refrigerant oil.
*Put the caps on the port from which the hose removed.
9. Measure pressure with a vacuum gauge.
Operating the vacuum pump for over 2hours after the pressure drops to -101kPa .

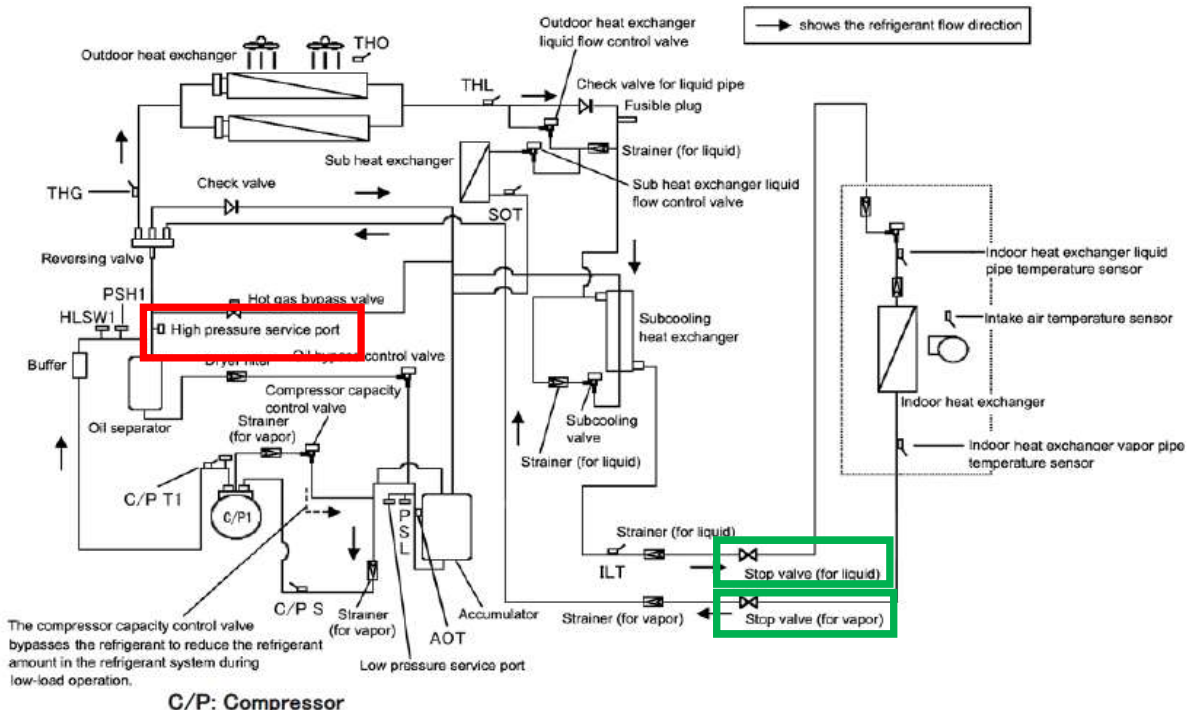

【Refrigerant oil refilling method】

●Refrigerant recovery of OUTDOOR UNIT only

●Outdoor unit type E model (450 / 560 / 710)

***Please be aware of the position hose connect, because there are check valves before and after the high-pressure service port.**

- After replacing parts, turn on the breaker of the outdoor unit.
- Set "Refrigerant recovery / Vaccuming operation (code No.06)" in the command mode.
*When set "Refrigerant recovery / Vaccuming operation (code No.06)" in the command mode, Remote control operation will be prohibited / Operation of outdoor units will be prohibited / Expansion valve and solenoid valve of indoor and outdoor units fully open.
- Connect the gauge manifold to service port of high-pressure(■*outlet side of check valve) and to service port of low-pressure(■).
Connect the gauge manifold to Vacuum pump and attach the Vacuum gauge.
*It is recommended to attach a control valve on the service port of high-pressure and low-pressure.
- Turn on the vacuum pump "ON" and perform vacuum suction.
It will be needed to perform vacuum suction a few minutes in order to suck up the refrigerant oil.
- Loosen the control valve of high pressure service port (■*outlet side of check valve) or close the gauge.
- Open the lid of refrigerant oil can and pour the specified amount of refrigerant oil into the beaker. Insert the hose for refilling the refrigerant oil into the beaker. (the side without a pin joint)
- Connect the hose (the side with a pin joint) for refilling the refrigerant oil to service port of high pressure(■*inlet side of check valve).
*Before this step, push the pin joint of the service port and confirm the refrigerant circuit pressure is low.
*Do not to attach a control valve. The refrigerant oil will not flow smoothly due to the control valve.
- Insert the hose fully into the refrigerant oil in order not to let in the air. Refill the specified amount of refrigerant oil.
- After refilling the refrigerant oil, cover the no-pin joint side of the hose with your finger in order not to let in the air in the hose for for refilling the refrigerant oil. Remove the hose for for refilling the refrigerant oil.
*Put the caps on the port from which the hose removed.
- After more than 10 minutes, tighten the control valve of high pressure service port (■*outlet side of check valve) or open the gauge.
*It must be took a Interval over 10 minutes after refilling the refrigerant oil, because it may happen backflow the refrigerant oil.
- Measure pressure with a vacuum gauge.
Operating the vacuum pump for over 2hours after the pressure drops to -101kPa .

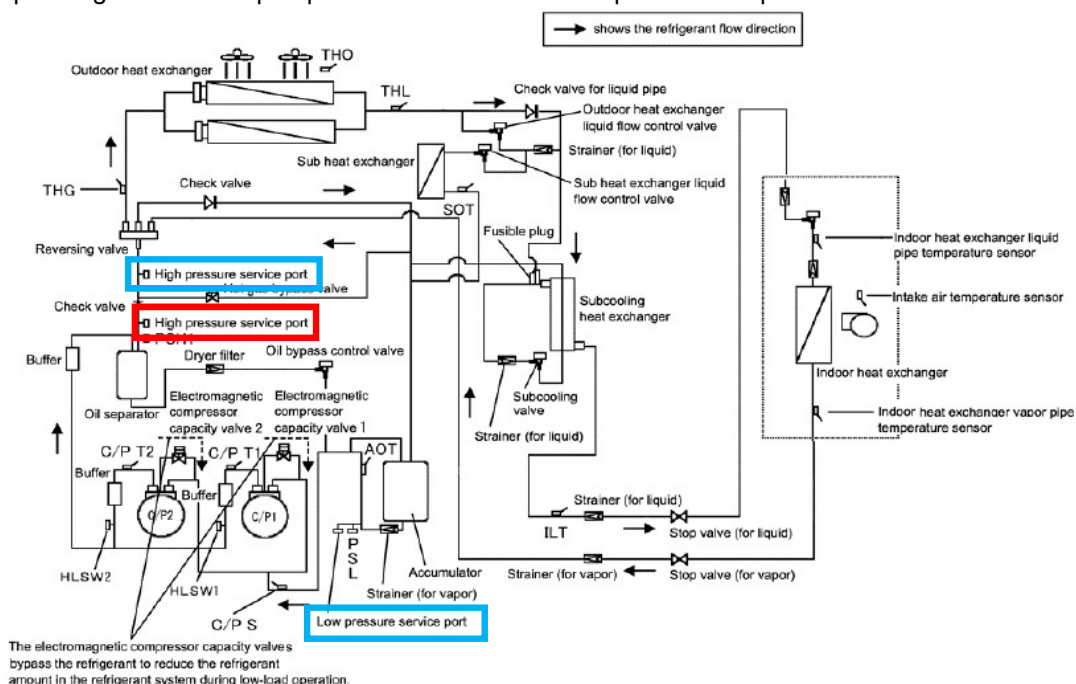

【Refrigerant oil refilling method】

●Refrigerant recovery of overall the system (OUTDOOR UNIT· INDOOR UNIT)

●Outdoor unit type

E model (450 / 560 / 710)

1. After replacing parts, turn on the breaker of the outdoor unit.
2. Set "Refrigerant recovery / Vaccuming operation (code No.06)" in the command mode.
*When set "Refrigerant recovery / Vaccuming operation (code No.06)" in the command mode, Remote control operation will be prohibited / Operation of outdoor units will be prohibited / Expansion valve and solenoid valve of indoor and outdoor units fully open.
3. Connect the gauge manifold to service port of stop valve for liquid(■) and service port of stop valve for vapor(■).
Connect the gauge manifold to vacuum pump and attach the vacuum gauge.
*It is recommended to attach a control valve on the service port.
4. Turn on the vacuum pump "ON" and perform vacuum suction.
It will be needed to perform vacuum suction a few minutes in order to suck up the refrigerant oil.
5. Open the lid of refrigerant oil can and pour the specified amount of refrigerant oil into the beaker. Insert the hose for refilling the refrigerant oil into the beaker. (the side without a pin joint)
6. Connect the hose (the side with a pin joint) for refilling the refrigerant oil to service port of high-pressure(■*inlet side of check valve).
*Before this step, push the pin joint of the service port and confirm the refrigerant circuit pressure is low.
*Do not to attach a control valve. The refrigerant oil will not flow smoothly due to the control valve.
7. Insert the hose fully into the refrigerant oil in order not to let in the air. Refill the specified amount of refrigerant oil.
8. After refilling the refrigerant oil, cover the no-pin joint side of the hose with your finger in order not to let in the air in the hose for for refilling the refrigerant oil. Remove the hose for for refilling the refrigerant oil.
*Put the caps on the port from which the hose removed.
9. Measure pressure with a vacuum gauge.

Operating the vacuum pump for over 2hours after the pressure drops to -101kPa .

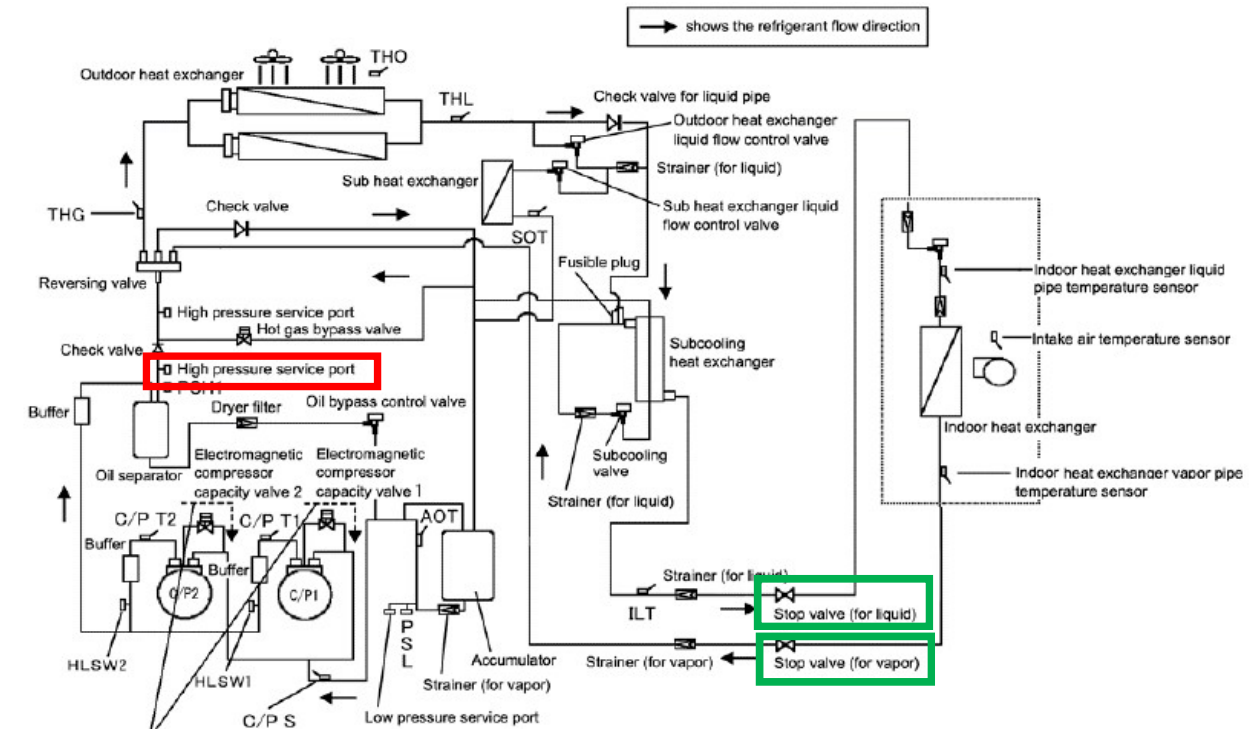

The electromagnetic compressor capacity valves bypass the refrigerant to reduce the refrigerant amount in the refrigerant system during low-load operation.